

COMEN

Specialized Fetal & Maternal Monitor

CF3/CF3A/CF30/CF30A/CF3 R/CF3A R/CF30 R/CF30A R

User Manual

Shenzhen Comen Medical Instruments Co., Ltd.

Copyright

Version: B00

No.: 046-00001925-00

Revision: 08/2025

Product Name: Specialized Fetal & Maternal Monitor

Product Model: CF3/CF3A/CF30/CF30A/CF3 R/CF3A R/CF30 R/CF30A R

Software Version: V1

Date of Manufacture: Refer to the Nameplate

Service life: 10 years

Company name: Shenzhen Comen Medical Instruments Co., Ltd.

Address: Floor 10, Floor 11 and Section C of Floor 12 of Building 1A & Floor 1 to Floor 5 of Building 2, FIYTA Timepiece Building, Nanhuan Avenue, Matian Sub-district, Guangming District, Shenzhen, Guangdong, 518106, P.R. China

Tel: +86-755-26431236 Fax: +86-755-26431232 Http: //en.comen.com



European Authorized Representative: Lotus NL B.V.

Address: Koningin Julianaplein 10, 1e Verd, 2595AA, The Hague, Netherlands.

Tel: +31644168999

Email: info@lotusnl.com

UK Responsible Person

Company Name: Lotus Global Co Ltd

Address: 23 Maine Street, Reading, RG2 6AG, England, United Kingdom.

Tel: 0044-20-70961611

Email: peter@lotusglobaluk.com

Statement

All rights reserved by Shenzhen Comen Medical Instruments Co., Ltd.

Shenzhen Comen Medical Instruments Co., Ltd. (hereinafter referred to as Comen or Comen Company) owns the copyright of this non-publicly published user manual and has the right to treat it as confidential information. This user manual contains proprietary materials protected by copyright law. All rights are reserved by Comen. No part of this user manual shall be photocopied, copied or translated into other languages without the prior written consent of Comen.

This user manual does not imply the transfer of any proprietary right under patent law to any third party. Comen shall not be liable for any legal consequences arising out of breach of the patent law or infringement of any third-party rights.

This manual only provides reference information for operation, maintenance and repair of Comen products. Comen hold the final explanation right of this manual. Comen shall assume no liability for any errors contained herein or any incidental or indirect damages arising from provision, actual performance or use of this manual.

The contents in this user manual are subject to change without prior notice.

Warranty

Comen will be responsible for the safety, reliability and performance of the product within the limited warranty period, if all of the following conditions are satisfied:

- The product is used in accordance with this manual.
- The product is installed, maintained or upgraded by approved or authorized personnel by Comen.
- The storage, operating and electrical environments for the product shall comply with the recommended information and product specifications contained in this manual.
- The serial number label or manufacturing mark of the product is clearly legible.
- The damage is not caused by human factors.
- All replaceable components, accessories, and consumables for maintaining are originally supplied by Comen or recognized by Comen.

Comen provides services free of charge for all products based on Comen's Warranty Service conditions. Comen may charge service fees for any service not within the product's warranty. The user shall bear any or all transportation costs (including customs duties) incurred during transportation of the products back to Comen.

Return Procedure

If you need to return the product to Comen, please follow the procedure below:

Request for product return: Contact Comen's after-sales service department and inform them of the product serial number marked on the product's nameplate. If the product serial number is not clear and legible, product return will not be accepted. Please indicate the product serial number, manufacturing date, and a brief description of the reasons for returning.

After-sales Service Department

Name: After-sales Service Department of Shenzhen Comen Medical Instruments Co., Ltd.

Address: Floor 5 of Building 2, FIYTA Timepiece Building, Nanhuan Avenue, Matian Sub-district, Guangming District, Shenzhen, Guangdong, 518106, P.R. China

Tel.: +86-755-26431236, +86-755-86545386, +86-755-26074134

Fax: +86-755-26431232

Customer Service Hotline: +86-755-4007009488

Preface

This user manual provides details on the performance, operations and safety instructions about the Specialized Fetal & Maternal Monitor (hereinafter referred to as the “monitor”). Please read carefully and understand the content of this manual so as to ensure the safety of the patients and operator.

This manual introduces the product of the most complete configurations. Some configurations or functions may not be available on the product you have purchased. If you have any questions, please contact us.

Please keep this manual near the device for easy and prompt access when needed.

Intended Users

This Manual is suitable for professional clinical personnel or those who are expected to have knowledge and work experience in medical procedures, practices, and terminology necessary to monitor patients.

Illustrations

All illustrations provided herein are for reference only. The menus, options, values and functions shown in the illustrations may be not exactly identical to those shown on the product.

Conventions

- →: This symbol is used to indicate operating steps.
- **[Character]**: This is used to represent character strings in the software.
- ***Bold and italic***: This is used to represent chapters quoted.
- **[Maintenance]** Password: 5188

Contents

Chapter 1 Safety	1-1
Safety Signs	1-1
Safety Information	1-1
Symbols	1-7
Cybersecurity	1-9
1.1 1.4.1 Running Environment	1-9
1.2 1.4.2 Data and Device Interface	1-10
1.3 1.4.3 User Access Control Mechanism	1-10
1.4 1.4.4 Security Software Upgrade	1-10
1.4.5 Cyber Security Information	1-10
Chapter 2 Product Overview	2-1
Product Introduction	2-1
2.1 2.1.1 Structure and Composition	2-1
2.1.2 Intended Use	2-1
2.1.3 Intended Patients	2-1
2.1.4 Contraindications	2-1
2.2 Monitor Appearance	2-2
2.2.1 Front View	2-2
2.2.2 Left View	2-3
2.2.3 Right View	2-3
2.2.4 Rear View	2-4
2.3 2.2.5 Bottom View	2-4
Monitor Accessories	2-5
2.4 2.3.1 Wireless Transducers	2-5
2.3.2 Wired Accessories	2-8
Screen Display	2-10
2.4.1 Patient Information, Alarm Information and Status Icons	2-12
3.1 2.4.2 Waveform Area	2-12
2.4.3 Shortcut Keys	2-12
3.2 2.4.4 Fetal Monitoring Interface	2-14
Chapter 3 Installation and Preparation	3-1
Installation Requirements	3-1
3.1.1 Unpacking and Checking	3-1
3.1.2 Environmental Requirements	3-1
Installation of the Battery	3-2

	Installation of the Monitor	3-2
	Installation of Recorder Paper	3-3
	Adjusting the Screen	3-4
	Connection of the AC Power Supply	3-4
	Equipotential Grounding	3-5
3.3	Connection of Accessories	3-5
3.4		
3.5	Start-up and Shutdown	3-6
3.6	3.9.1 Start-up	3-6
3.7	3.9.2 Shutdown	3-6
3.8		
	Chapter 4 Basic Operations	4-1
	Main Menu	4-1
	System Setup	4-1
4.1	4.2.1 Volume	4-1
4.2	4.2.2 Screen Brightness	4-1
	4.2.3 Units	4-1
	4.2.4 Screen Color	4-2
	4.2.5 Module Color	4-2
	4.2.6 Night Mode	4-2
	4.2.7 Custom Shortcuts	4-2
4.3	User Maintenance	4-3
	4.3.1 Date and Time	4-3
	4.3.2 Alarm	4-3
	4.3.3 Configuration Management	4-3
	4.3.4 Network Setup	4-3
	4.3.5 Language Setup	4-5
	4.3.6 Version	4-5
	4.3.7 Battery Information	4-5
	4.3.8 Scanner Setup	4-5
	4.3.9 Print Setup	4-5
4.4	4.3.10 Monitor Location	4-6
	4.3.11 Demo Mode	4-6
	4.3.12 Patient Information Management	4-6
	4.3.13 Patient File Management	4-7
	Work Modes	4-7
	4.4.1 Monitoring Mode	4-7
	4.4.2 Night Mode	4-7

	4.4.3 Demo mode	4-8
	Chapter 5 Fetal Monitoring	5-1
	Safety Information	5-1
	Confirming Fetal Life	5-1
	Fetal Setup	5-1
	5.3.1 Fetal Movement Volume.....	5-1
5.1	5.3.2 UA Baseline Setup	5-2
5.2	5.3.3 AFM Setup.....	5-2
5.3	5.3.4 FM Source	5-2
	5.3.5 AFM Mode	5-3
	5.3.6 Smart Note	5-3
	5.3.7 CTG Score	5-3
	5.3.8 Cross Duration and Cross Error	5-3
	Monitoring Setup	5-4
5.4	5.4.1 Fetal Volume	5-4
	5.4.2 Auto Print	5-4
	5.4.3 Patient Information Setup.....	5-4
5.5	FHR1/2 Setup	5-4
	5.5.1 Alarm Switch	5-4
	5.5.2 Alarm Level	5-5
	5.5.3 Alarm Limit.....	5-5
	5.5.4 Upper/Lower Limit Alarm Delay.....	5-5
5.6	5.5.5 Weak Signal Alarm	5-5
5.7	TOCO Setup	5-6
5.8	FM Setup	5-6
	FHR Monitoring.....	5-6
5.9	5.8.1 Testing Ultrasound Transducers	5-7
	5.8.2 FHR Monitoring with Ultrasound	5-8
5.10	5.8.3 Monitoring Twin FHRs with Ultrasound	5-9
	TOCO Monitoring	5-10
5.11	5.9.1 Testing TOCO Transducers.....	5-10
	5.9.2 TOCO Monitoring with a TOCO Transducer.....	5-11
	Monitoring Fetal Movement.....	5-12
	5.10.1 AFM Monitoring.....	5-12
	5.10.2 MFM Monitoring.....	5-12
	Start Monitoring.....	5-13

	5.11.1 Inputting Patient Information	5-13
	Chapter 6 Alarms.....	6-1
	Safety Information	6-1
	Alarm Types.....	6-1
	Alarm Signals.....	6-2
	6.3.1 Alarm Indicator	6-2
6.1	6.3.2 Audible Alarm	6-2
6.2	6.3.3 Alarm Messages.....	6-2
6.3	6.3.4 Alarm Parameter Flashing.....	6-3
	6.3.5 Alarm Status Icons.....	6-3
	Parameter Alarm ON/OFF	6-3
	Alarm Levels	6-3
6.4	6.5.1 Set Alarm Level	6-4
6.5	Set Alarm Limit.....	6-4
6.6	Alarm Setup	6-4
6.7	6.7.1 Volume.....	6-4
	6.7.2 Pause/Reset	6-5
	6.7.3 Other	6-7
6.8	Alarm Reset.....	6-7
	6.8.1 Physiological Alarm Reset	6-7
6.9	6.8.2 Technical Alarm Reset	6-7
	Alarm System Test	6-8
7.1	Chapter 7 Review	7-1
7.2	Overview	7-1
7.3	Search Patient Information	7-1
	Fetal Review	7-2
7.4	7.3.1 Enter/Exit the Fetal Review Interface.....	7-2
	7.3.2 Fetal Monitoring Review Interface.....	7-2
	7.3.3 Print Fetal Monitoring Waveform	7-3
8.1	Alarm Review	7-4
8.2	7.4.1 Enter/Exit Alarm Review Interface.....	7-4
8.3	7.4.2 Alarm Review Interface.....	7-4
	Chapter 8 Print	8-1
	Overview	8-1
	External Printer	8-1
	Recorder Paper.....	8-1

	Print Setup	8-2
	8.4.1 Recording Setup of Fetal Monitoring	8-2
	Event Marks	8-7
	Start Recording/Printing	8-8
8.4	8.6.1 Start Recording Manually	8-8
	8.6.2 Start Printing Manually	8-8
8.5	8.6.3 Start Recording Automatically	8-8
8.6	Stop Recording/Printing	8-8
	8.7.1 Stop Recording Manually	8-8
	8.7.2 Stop Recording/Printing Automatically	8-8
8.7	Paper Advancing	8-8
	Clear Paper Jams	8-9
8.8	Cleaning of the Recorder	8-9
8.9	Chapter 9 CTG Score	9-1
8.10	Chapter 10 Battery	10-1
	Overview	10-1
10.1	Viewing Battery Information	10-2
10.2	Conditioning and Checking Battery Performance	10-2
10.3	10.3.1 Conditioning Battery Performance	10-2
	10.3.2 Checking Battery Performance	10-2
10.4	Battery Recycling	10-3
11.1	Chapter 11 Cleaning and Disinfection	11-1
11.2	Overview	11-1
11.3	Cleaning of the Monitor	11-2
11.4	Disinfection of the Monitor	11-3
11.5	Cleaning and Disinfection of Accessories	11-3
12.1	11.4.1 Cleaning and Disinfection of Other Accessories	11-3
12.2	Sterilization	11-4
12.3	Chapter 12 Maintenance	12-1
12.4	Maintenance and Checks	12-1
	Reusable Accessory Service Life	12-2
	Maintenance Schedule	12-2
	Testing Methods and Steps	12-2
	12.4.1 Visual Inspection	12-3
	12.4.2 Startup Inspection	12-3
	12.4.3 Recorder Inspection	12-3

	12.4.4 Battery Inspection	12-3
	12.4.5 Disposal of Monitor and Accessories	12-3
	Testing Ultrasound Transducers	12-3
	Testing TOCO Transducers	12-4
	Accessories	I-1
	Product Specifications	II-1
12.5	System Alarm Information	III-1
12.6	Default Configuration	IV-1
Appendix I	EMC.....	V-1
Appendix II	Abbreviation and Terms.....	VI-1
Appendix III	Limitations of Ultrasound Monitoring	VII-1
Appendix IV	Mechanical Index (MI) and Thermal Index (TI)	VIII-1
Appendix V		
Appendix VI		
Appendix VII		
Appendix VIII		

Safety Signs

1.1



WARNING

- Alerts you to situations that may result in serious consequences or adverse events or endanger personal safety. Failure to observe the warning information may cause severe injury or even death of the user or patient.



CAUTION

- Alerts you to potential dangers or unsafe operations, which, if not avoided, may result in minor injury, product failure or damage, or property damage, or cause more serious injury in the future.



NOTE

- Emphasizes important precautions and provides instructions or explanations for better use of the product.

1.2

Safety Information



WARNING

- To ensure the normal operation of the monitor and the safety of the user and the patient, please read this chapter before use. The installation and connection of the monitor shall be conducted by maintenance personnel.
- The monitor shall be installed by qualified maintenance personnel.
- No modification by the user to the device shall be performed.
- The monitor is not intended for the use in ICU, operating room or at home.
- The device cannot be used for clinical monitoring until the device and accessories are correctly connected and calibrated.
- Do not use the device in the presence of flammable anesthetics to avoid explosion.
- To ensure the safety of the patient and the operator, the device shall be connected to a power socket with protective grounding and its housing shall be grounded. Do not connect the 3-wire cable of this

monitor to a 2-wire outlet.

- A protective grounding conductor is required for electromagnetic compatibility reasons. The monitor has no protection against electric shock. Double insulation and/or enhanced insulation protects the device against electric shock.
- Do not place the mobile multi-plug outlet on the ground.
- The mobile multi-plug outlet that power the device shall only be used to power the equipment consisting of the system. Non-system electrical equipment connected to the outlet may cause the total power exceeding the maximum load of the isolation transformer to trigger the risk of heat and fire; or may also cause leakage currents in the enclosure between devices to exceed standard limits to generate electric shock to the operator or the patient.
- Do not connect or disconnect the power supply with wet hands.
- Do not touch the signal I/O ports and the patient simultaneously.
- Only approved analog or digital equipment in accordance with the specified IEC standards (like IEC 60950 safety standards for Information Technology Equipment, IEC 60601-1 safety standards for medical electrical equipment, etc.) are allowed to be connected to the monitor. All configurations should comply with the valid version of the standard IEC 60601-1. Personnel who connect external equipment to the signal I/O ports of the monitor should verify that medical system complies with IEC 60601-1 requirements, before configuring the medical system and connecting the external equipment. If there is any doubt, contact us or the local agent.
- Connecting any accessory (e.g. external printer) or device (e.g. computer) to the monitor can form a medical system. At this moment, additional safety measures should be taken when installing the system, and the system shall comply with the following requirements.
 - a) Within the patient environment, the system shall meet the requirements of safety for medical equipment specified by IEC/EN 60601-1.
 - b) Outside the patient environment, the system shall meet the requirements of safety for non-medical equipment specified by other IEC or ISO safety standards
 - c) All accessories to be connected to the device must meet the requirements of IEC/EN 60601-1.
- Using accessories, energy converters or cables other than specified by the manufacturer may cause higher electromagnetic emission or lower electromagnetic immunity.
- Do not place the power plug used to disconnect the device from supply mains in a position not easily accessible to the operator.
- Use the lead cable or other supporting accessories provided by the manufacturer only to ensure the performance and safety of the device.
- If a multi-plug outlet is used, the total system power consumption calculated at the time of installation of this system should not exceed the power of the outlet. The maximum allowable load is shown on the label or silkscreen of the outlet.
- Non-medical electrical equipment comprising the system can only be connected to the provided mobile multi-plug outlet with isolation transformer. If the equipment is connected directly to the wall outlet, this may result in leakage currents to ground and enclosure exceeding the standard limits. The isolation of non-medical electrical equipment and the mains power may not meet the

requirements of medical electrical equipment, resulting in electric shocks to the operator or the patients.

- **Assembly other than specified by the system components cannot connect to the system.**
- **Use assembly compatible with the system to reduce the danger of the doctor and the patient.**
- **Do not stack this product on/under or get it close to any other equipment. If you have to use it this way, observe and verify whether it works properly in such conditions first.**
- **Do not use the monitor and other ultrasound devices simultaneously on a patient to avoid the possible danger caused by the superposition of leakage. Do not use the monitor and other devices, such as pacemakers, electrical stimulators, etc., on the patient simultaneously.**
- **Do not place the TOCO transducer on edema or fragile sites and change the measurement site every half hour.**
- **The monitor can only be used for one patient at a time.**
- **Do not open the housing of the monitor to avoid the potential risk of electric shock.**
- **Any equipment connected to the monitor shall form an equipotential circuit (effective connection of protective ground).**
- **To ensure the safety of the doctor or the patient, do not use the monitor during the use of electrosurgical equipment (including high frequency surgical equipment) or MRI.**
- **Do not place any non-medical equipment (e.g. external printer) around the patient.**
- **Before connecting or disconnecting the device from the power cord, ensure that the monitor is turned off and the power plug is removed from the outlet, to avoid the risk of electric shock or injury to the patient or the operator.**
- **The components and accessories shall comply with the requirements of IEC 60601 series standards. The system settings of the device shall also comply with the requirements of IEC 60601-1.**
- **Do not reuse disposable accessories or accessories intended for the use of a single patient, to avoid possible damage to the device functions and system performance or potential danger.**
- **Place the cables appropriately to avoid personal entanglement or stumble.**
- **Do not perform repairs or maintenance on monitors or accessories during monitoring.**
- **Within the period of validity, the installation of the device should be evaluated for the requirements of IEC60601-1.**
- **At the end of the device's service life, the monitor and its recyclable accessories can be returned to the manufacturer for recycling or be disposed of in accordance with local regulations.**
- **The device is precision instrument, and the touch screen is especially fragile. Keep the device from violent operation, dropping or collision to avoid device damage.**
- **To avoid delayed treatment, adequate alarm settings should be set depending on the patient, and the monitor shall sound the alarm.**
- **The physiological waveforms, physiological parameters and alarm information displayed on the monitor are for reference only and shall not be used as the direct basis for clinical treatment.**
- **Prior to use the rechargeable battery, read this manual and the safety instruction carefully.**
- **The battery shall only be used for the monitor.**

- The positive and negative terminals of the battery must not be reversed, otherwise it may cause an explosion.
- Before using the device, please manual carefully. Incorrect operation may heat the battery, cause fire, explosion or damage, or decay the battery capacity.
- Do not heat the battery or throw it into fire.
- Do not use the battery near a source of ignition or in an environment temperature outside the specification in this manual.
- Do not place the battery in water or in a location where it may be submerged in water.
- Do not damage the battery. Do not chisel into the battery with metal, hammer or drop the battery or damage the battery by other means, to avoid heat, smoke, deformation, fire and other risks.
- If the battery falls off or collides with a hard surface, stop using it whether or not the damage can be identified from the appearance.
- Keep the battery and other accessories appropriately and out of the reach of children.
- Do not weld the battery directly.
- If the battery electrolyte comes into contact with your skin or clothes, wash it with clean water immediately.
- If the battery electrolyte enters your eyes, do not rub your eyes and wash them with clean water immediately and seek medical help.
- Keep away from the battery immediately when leakage is found or unpleasant odor is emitted.
- At the end of the service life of the battery, or when strange smell, deformation, discoloration or distortion present, stop using it and dispose of the battery in accordance with local regulations.
- If the device is not used for a long time, please remove the battery and store it separately, and please charge and discharge the battery of wireless transducers regularly.
- Batteries should be charged, used and stored in a place away from static electricity.
- It is recommended to replace the aging battery.
- To prevent the battery from being unusable due to over-discharge, if the battery is not used for a long time, it is recommended to do regular inspection and maintenance of the battery every 3-6 months.
- If the battery is installed in the monitor for a long time and not connected to the AC power, it may slowly discharge over time, and the indicator for remaining power may be inaccurate.
- To avoid possible fire or explosion, use the battery provided by the manufacturer only.
- High internal temperature may cause the battery to not charge. Keep the monitor at room temperature and away from heat sources or direct sunlight. When the temperature becomes normal, the battery can be charged.
- High-load operation of the monitor (multiple measurements being conducted) may cause the battery to not charge.
- If the button cell battery is required, it shall be replaced by a service engineer authorized by the manufacturer.

- Please do not replace the wireless transducer battery without permission. If required, please contact Comen or qualified service personnel authorized by Comen.
- A periodic functional test should be performed inside this monitor.
- Do not transport the monitor in charged state. Do not soak the monitor in any liquid.
- Check the ultrasound transducer periodically. If there is any damage to the housing, repair it immediately.
- Check if the housing of the transducer is intact after being dropped or hit. If there is any question, contact the manufacturer or the local agent immediately.
- Do not use damaged probes.
- Systems running at less than minimum amplitude or minimum value may result in inaccuracies.
- The Thermal indices and mechanical index are 1.0 or less for all device settings.
- If any serious incident has occurred in relation to the device, please report to Comen and the competent authority of the Member State in which the user and/or patient is established.



CAUTION

- The monitor is an ordinary device intended for continuous operation. Avoid water splashes.
- Equipment maintenance can only be conducted by designated maintenance personnel.
- Do not transport the monitor in charged state. Keep the monitor clean, and away from vibration, corrosive materials, high humidity, high heat and direct sunlight.
- If the monitor is installed in the monitor cabinet, enough space in the front is required for the ease of operation. If the cabinet door is open, there should be enough space behind for maintenance. Air circulation in the cabinet should be ensured.
- During operation, it is necessary to ensure that the device is free from condensation. Condensation may form as the instrument is moved from one room to another. This is because the instrument is exposed to moist air and different temperatures.
- The monitor and its accessories should not be disinfected with an autoclave or gas.
- Before cleaning, turn off the power supply and the monitor.
- The monitor complies with the EMC requirements of IEC 60601-1-2.
- The monitor complies with the requirements of Group 1 Class A of IEC/CISPR11.
- Materials in contact with the human body complies with the requirements of ISO 10993-1: 2009.
- The user shall install and operate the device in accordance with the EMC information provided in the accompanying documents.
- Ensure that there are no large CT machines, nuclear magnetic oscillation equipment, wireless transmitters, or other strong electromagnetic sources within the environment where this monitor will be used. The monitor may be interfered with by other equipment even if other equipment meets the emission requirements of appropriate national standard.
- Performance can be affected by mobile and portable RF communications equipment. Do not use

mobile phones, microwave ovens, and other electromagnetic devices near this monitor to avoid strong electromagnetic interference.

- Fetal parameters, especially ultrasound and ECG, are sensitive measurements involving small signals. This monitor contains very sensitive high-gain front-end amplifiers, and the immunity to RF electromagnetic fields and conducted interference caused by RF sites is limited by the technology. To avoid incorrect test results due to external magnetic fields, it is recommended to avoid using electrical radiation equipment in the vicinity of these measurement components
- Do not stack this product on/under or get it close to any other equipment unless otherwise stated.
- The phenomenon of electromagnetic interference is not unique to this monitor but is common. The monitoring function is derived from the very sensitive high gain front-end amplifier that processes the subtle physiological signals from the pregnant woman. Interference from electromagnetic sources has rarely been a problem in any of the many monitors that have been used in clinical practice.
- Two-way radios may affect network stability and cause network dropouts. Do not use two-way radios near the monitor.
- Batteries have a life span. If the monitor operates for much shorter hours than usual on battery power, the battery has reached its end of service life and a new one is required. When replacing the battery, contact the manufacturer for replacement.
- To avoid the device damage and ensure the patient's safety, use the accessories specified in the manual only.
- Place the device appropriately to prevent the device from being dropped, collision, strong vibration or any external mechanical forces.
- Before powering on the device, make sure that the power supply meet the requirements of the power supply voltage and frequency specified on the nameplate or in the manual.

**NOTE**





















- Place the monitor at a position where observation, operation and maintenance are convenient.
- This manual is based on the maximum configuration; therefore, some contents may not be applicable to your monitor.
- Keep this manual available for ease of use and convenient reference.
- This device has not been sterilized before delivery. Be sure to clean and sterilize it before using for the first time.
- The responsibility for the use and maintenance management of medical electrical devices rests with the user (hospital, clinic). Non-professional use of the monitor is not allowed.
- In order to keep this equipment in the optimal condition at all times, regular maintenance is required.
- In case of abnormality or malfunction of the equipment, mark the "malfunctioning" sign and contact your local agent or a service engineer immediately.
- In the event of an abnormality or malfunction, to prevent danger, do not use the equipment until













repairs by personnel specified by the manufacturer is completed.

- Be sure to observe the precautions in the manual to use the equipment correctly. Only trained personnel can operate the monitor. Do not use this equipment for purposes other than those specified
- Clean and disinfect the device regularly in accordance with relevant hospital regulations and with the requirements in the manual.
- Please select the correct operating voltage in accordance with the input voltage requirements.
- In normal use, the operator's position shall be within 1 meter of the device.













Symbols

1.3 ● Device Symbols

Symbols	Description	Symbols	Description
	Caution		Warning
	European Authorized Representative		Complies with Medical Devices Regulation (EU) 2017/745
	Refer to instruction manual		Serial number
	ON/OFF button		Type CF applied part
IPX0	IP degree of the enclosure	IP68	IP degree of transducers
	USB port		Computer network
	Battery indicator		Serial interface
	Ac power indicator		Rechargeable battery
	Equipotentiality		Protective earth
	AC power connector		Alarm reset
	Alarm audio paused		Alarm audio off

	Alarm off		Alarm paused
	OFF		ON
	Signal quality indicator		Search
	Ultrasound transducer connector; TOCO transducer connector		Sequence
 EXT.1	Fetal stimulator connector		Signal strength
 MARK	Remote event marker connector		Transducer placement guide

● Packaging Symbols

Symbols	Description	Symbols	Description
	This way up		Stacking limit by number
	Fragile, handle with care		Keep away from rain
	Temperature limitation		Humidity limitation
	Atmospheric pressure limitation		Serial number
	Imported and distributed by		Catalogue number
	Unique Device Identifier		Authorized representative in the European Community
	The product conforms to the requirements of the Regulation (EU) 2017/745 MDR on medical devices.	/	/

Cybersecurity

1.4.1 Running Environment

1.4.1.1 Hardware Configuration

No.	Name	Specification
1	CF3 Main Control Board	CM_CF3_MAINBOARD
2	Fetal Parameter Board	CM_CF_FETAL_BOARD
3	Alarm indicator board	CM_CF3_ALARM
4	CF3 USB/NET Interface Board	CM_CF3_USB_NET
5	CF3 Side Panel	CM_CF3_SIDE
6	Side wireless charging board	CM_CF3_NFC CHARGE
7	Ultrasound transducer	CM_CF_FETAL_WIFIEXPROBE
8	TOCO transducer	CM_CF_TOCO_PROBE_ECG
9	CF3 Switch button board	CM_CF3_POWER_CON
10	CF3 screen adapter board	CM_CF3_24bit_LCD_CON
11	CF3 RS232 interface board	CM_CF3_RS232

1.4.1.2 Software Configuration

No.	Name	Version
1	uboot	V1.0.0
2	zlmagedtb	V1.0.0
3	rootfs.gz	V1.0.0
4	Logo.gz	COMEN
5	Main	V1.0.0

6	Single-chip microcomputer program	V1.0.0
---	-----------------------------------	--------

1.4.1.3 Network Requirements

The network requires private line Internet with an independent public IP address and a firewall configured. The bandwidth (both upstream and downstream) shall be not less than 50M.

1.4.2 Data and Device Interface

Type	Quantity	Communication protocol
Multi-function output interface	1	/
USB interface	2	USB communication protocol
Network interface	1	TCP/IP protocol
NFC interface	3	ISO/IEC 14443
Wi-Fi interface	1	IEEE802.11 a/b/g/n protocol
Wi-Fi interface	1 (host side) 3 (probe side)	UART protocol; Wireless US and TOCO transmission protocol (data format: frame header (two bytes) + packet length (one byte) + packet ID (one byte) + packet (indeterminate length) + frame end checksum (one byte))

1.4.3 User Access Control Mechanism

Different passwords shall be provided as a method of user identification to identify the user as an ordinary user, maintenance personnel or system administrator.

- Ordinary users, maintenance personnel and system administrators can enter the user maintenance page with a specified password to modify module settings.
- Maintenance personnel and system administrators can enter the manufacturer maintenance page with a specified password to modify module settings.

1.4.4 Security Software Upgrade

The security software shall be upgraded by specified personnel of the manufacturer.

1.4.5 Cyber Security Information



WARNING

- Improper use of the device could cause hazards to patients and device performance.
- Do not connect to an unrecognized or unsecured network.
- Before connecting the device to other instruments, ensure that any connected device is free of malware.
- No other remote control is allowed.
- For embedded device, the security update is integrated with the software update. The update is only allowed by authorized personnel.
- When the syringe pump reaches the end of service life, erase patient data and configuration data before disposal.



CAUTION

- Make sure the USB devices are free of malware before inserting to the device.
- If the device is disconnected from the Central Monitoring System, the communication error alarm will be triggered in the device.
- Connection to IT-NETWORKS including other equipment could result in previously unidentified RISKS TO PATIENTS, OPERATORS or third parties.
- Modification to the device could cause faults and electromagnetic interference. The RESPONSIBLE ORGANIZATION should identify, analyze, evaluate and control these RISKS.
- Changes to the IT-NETWORK could introduce new RISKS that require additional analysis. Changes to the IT-NETWORK include:
 - changes in network configuration
 - connection of additional items
 - disconnection of items
 - update of equipment
 - upgrade of equipment



NOTE

- The device is intended to be used in professional healthcare facilities by professional healthcare personnel.
- It is important to note that any facility using the device and Central Monitoring System must take measures to protect the privacy of the patient's personal information in accordance with the local regulations and the facility's policies for managing this information.
- If the device is connected to the Comen Central Monitoring System, an anti-virus software is required to be installed on the host server. Refer to the user manual of Central Monitoring System for more information.
- No software installation is required for the embedded device.
- Comen will provide the software bill of material on the request of the user.

Chapter 2 Product Overview

The equipment is designed to meet the relevant national and international safety standards for medical electrical equipment.

Product Introduction

2.1.1 Structure and Composition

2.1

The product consists of a main unit (the battery, the holder, the display, the recorder and the housing) and corresponding functional accessories (wired/wireless ultrasound transducers, wired/wireless TOCO transducers, the remote event marker and fetal stimulators).

2.1.2 Intended Use

This product is intended for use in hospital to monitor the TOCO, fetal heart rate and fetal movement.

This product is expected to be used in the labor and delivery room, in the prenatal examination room, and during postpartum recovery.

All models of monitors shall be operated by trained health care professionals.

2.1.3 Intended Patients

This product can provide physiological parameters monitoring for the patients with over 24 weeks of pregnancy.

2.1.4 Contraindications

None.

Monitor Appearance

2.2.1 Front View

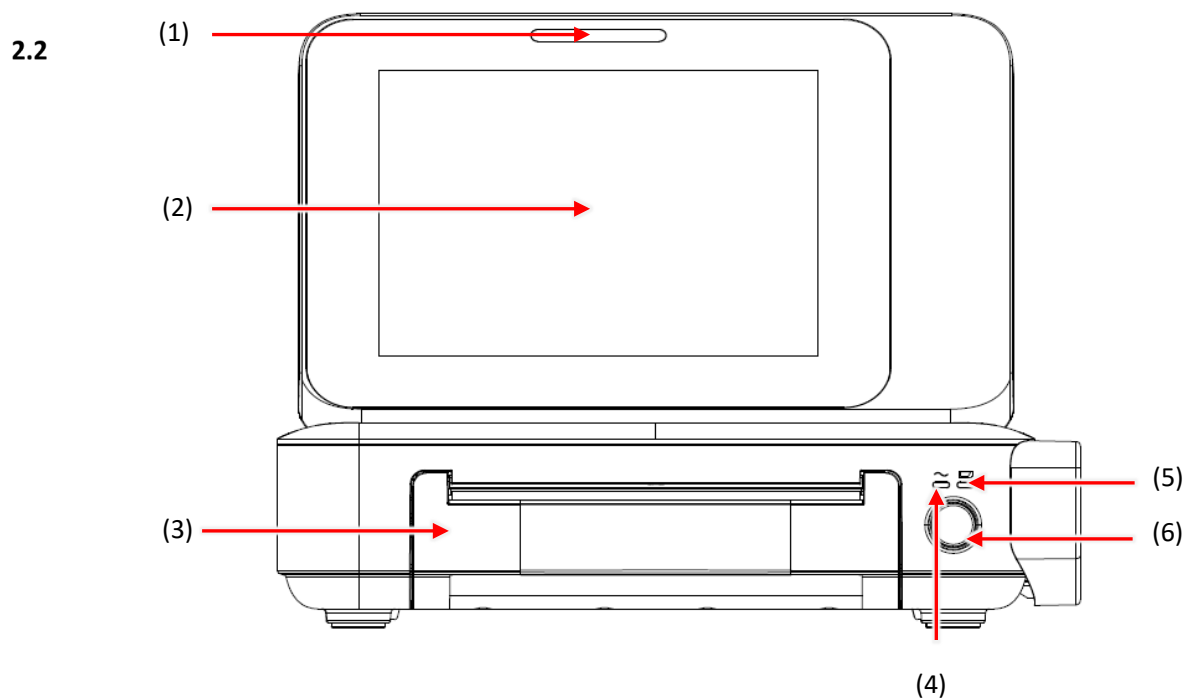

1. Alarm indicator
 - ◆ It indicates alarm levels with different light colors and flashing frequencies.
2. Display (touch screen)
 - ◆ The software interface is shown on the display, and touch the screen to select or change a setting.
3. Paper compartment
4. AC power indicator
 - ◆ Indicator on: this monitor is connected to an AC power supply.
 - ◆ Indicator off: this monitor is not connected to an AC power supply.
5. Battery indicator
 - ◆ Indicator on: battery is being charged.
 - ◆ Indicator flashes: battery is used to supply power to the monitor.
 - ◆ Indicator off: battery is fully charged, is not installed or has malfunctioned.
6. ON/OFF button (with an indicator)
 - ◆ Press the button to turn on/off the monitor. The indicator is on when the monitor is turned on and is off when the monitor is turned off.

2.2.2 Left View

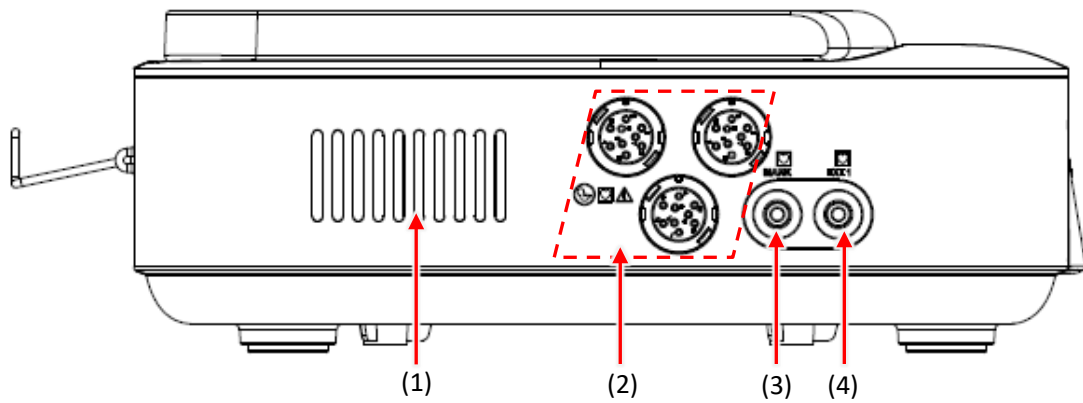

- | | |
|-----------------------------------|---|
| (1) Speaker | (2) Ultrasound and TOCO transducer connectors |
| (3) Remote event marker connector | (4) Fetal stimulator connector |

2.2.3 Right View

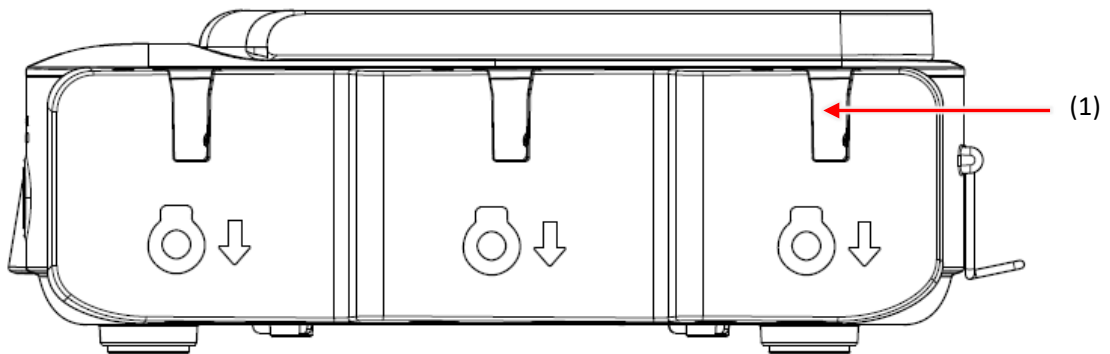

1. Wireless transducer charging station/Transducer holder
 - ◆ Wireless or wired ultrasound transducers and TOCO transducers can be placed.
 - ◆ Charge the wireless transducers.

2.2.4 Rear View

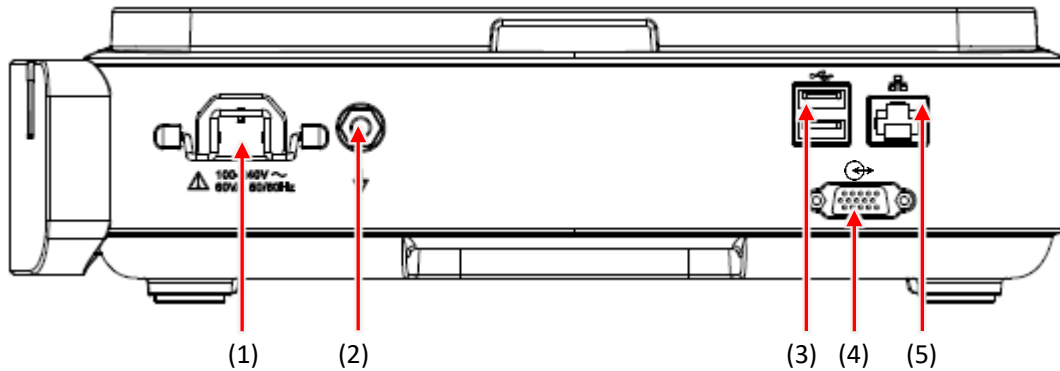

1. AC power connector
2. Equipotential connector
 - ◆ When the monitor is used together with other equipment, use a wire to connect the equipotential terminals with the other equipment. This eliminates the ground potential difference, thus ensuring safety.
3. USB connector
 - ◆ Connects to USB equipment, such as USB mouse and scanner, or to upgrade software.
4. Serial Interface
 - ◆ Connects to the system.
5. Network connector
 - ◆ Networks with the Central Monitoring System (CMS) or other equipment via standard network cables.

2.2.5 Bottom View

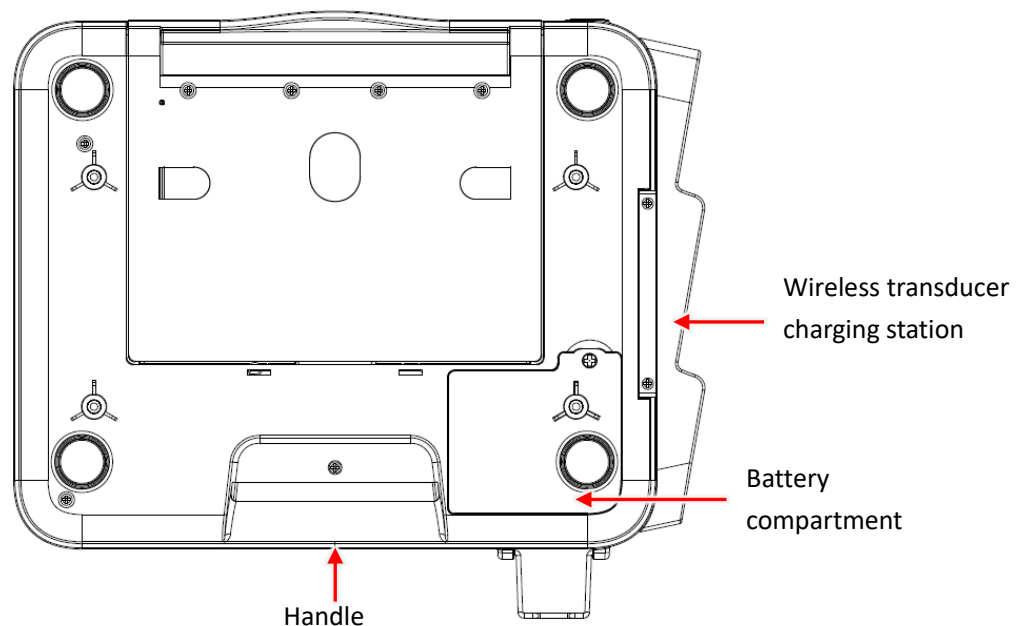

Monitor Accessories

 **NOTE**

- 2.3 ● Different accessories are equipped for different models of monitors. This manual introduces the device based on the maximum configuration.

2.3.1 Wireless Transducers

Wireless transducers include wireless TOCO transducers and wireless ultrasound (US) transducers.









(1) Wireless TOCO Transducer

(2) Wireless Ultrasound Transducer

2.3.1.1 Display of Wireless Transducers

When the wireless transducer is being charged at the charging station, the following symbols will be shown:

- During charging, these icons      are shown in turn.
- When the charging is complete, a fully charged battery icon  will be displayed.

When the wireless transducer is taken out from the charging station, it turns on automatically and the display is shown as follows

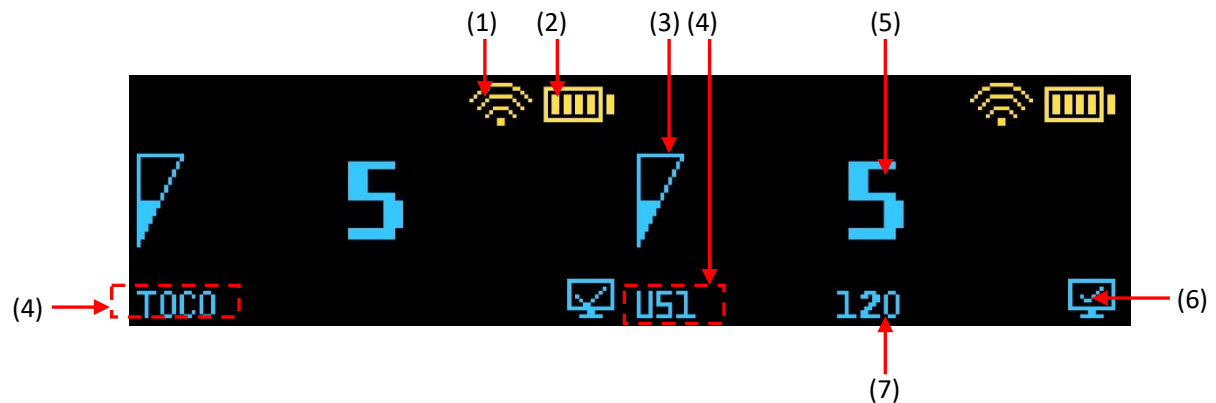

(1) Wireless signal indicator, which has 4 degrees: 

(2) Battery indicator, which has 5 degrees: 



(3) US fetal heart signal quality indicator, which has 3 degrees: 

(4) Transducer type

If a US transducer is used, US1/2 will be displayed in accordance with the sequence of the transducer being taken out from the charging station. If a TOCO transducer is used, **TOCO** will be shown.

(5) Device number of the bedside monitor

(6) Transducer connection indicator

The  icon will be shown if the transducer is connected to the monitor successfully. If not,  will be shown and the transducer will be automatically turned off in 15min.

(7) Fetal heart rate for US transducers; TOCO value for TOCO transducers



NOTE

- The patient should move in limited areas where the signal is good.
- During monitoring, place the wireless US transducer on the location where the fetal heart signal is the strongest and fix the transducer with a belt to ensure that it is securely positioned during movement.
- During monitoring, apply an appropriate amount of coupling gel to the wireless US transducer. Insufficient gel may lead to poor FHR signal transmission.

2.3.1.2 Charging Wireless Transducers

A rechargeable lithium battery is installed in the provided wireless transducer. When the monitor is connected to an AC power, place the transducer in the charging station, a “dee” will be sounded and the indicator on the charging station turns green. A charging icon and the battery level icon will be shown on the display of the transducer. Then the transducer is correctly placed and is being charged. When the monitor is not connected to an AC power but powered by a battery, place the transducer in the charging station, a “dee” will be sounded and the indicator on the charging station turns green and only the battery level icon is displayed. Then the transducer is correctly placed but is not being charged.

During use, please pay attention to the battery power of the transducer to avoid insufficient power; otherwise the monitoring may be affected. The battery icon on the upper right corner of the transducer display indicates the battery power.

 indicates the battery is full.

 indicates the battery power is sufficient.

 indicates the battery power is not sufficient.

 indicates the battery is too low and should be charged immediately.

 indicates the battery is depleted and should be charged immediately.



NOTE

- **Before charging the wireless transducer, please clean it carefully with a dry cloth to make sure there is no water and no coupling gel residue. When the transducer is charged in the charging station, make sure that it is well placed and is being charged.**
- **After the charge is completed, wait for 2 minutes before using the transducer.**
- **The temperature of the wireless transducer will increase during charging, but the temperature will not increase by more than 20°C.**
- **When the monitor alarm indicates that the battery of the wireless transducer is low, charge the wireless transducer immediately, otherwise it will automatically turn off and the monitoring will be interrupted.**

2.3.1.3 Mobile Monitoring

When the patient moves during monitoring, signal interference may appear. Artifact may be present during the patient's movement. Some artifact can be expected but some can only be detected through the observation of the signal. The artifact can affect the quality of signal transmission. If a wireless transducer is used in a changing environment, it may cause drop out or other interference. If there is problem with transmission, the patient can leave the current places, such as the elevator or the window with metal, for better signal strength.

The wireless transducer should be placed at the location where the fetal heart signal is the strongest. Pay attention to the following during monitoring, especially when patient is walking:

- Record the effective FHR.
- Pay attention to the tightness of the belt to ensure that the transducer is securely and appropriately placed.
- The patient should move, without stamping, as instructed within limited areas where the signal is good.



WARNING

- **The collection of fetal heart rate and TOCO value may be affected if the patient is walking. The patient is recommended to walk as less as possible during monitoring and to avoid vigorous and excessive movement.**
- **The manufacturer has no control over the RF environment in which the monitor is used. If interference occurs in the operating frequency, the device performance will be affected. If interference is detected, move the monitor away from the interference.**

2.3.1.4 Turn off the Transducer

- 1) Click the FHR parameter area on the screen.
- 2) Select the target transducer to turn it off.

2.3.2 Wired Accessories

Wired accessories include: wired ultrasound (US) transducers, wired TOCO transducers, remote event marker and fetal stimulator.

2.3.2.1 Wired US Transducer and Wired TOCO Transducer



(1) Wired TOCO Transducer (2) Wired US Transducer Indicators (3) Wired US Transducer



NOTE

- The indicators on the wired US transducer can be used to distinguish the wired US transducer 1/2. If the first indicator is lit, it means the transducer connected is US1; if the first and second indicators are lit, then US2 is used.
- When a wired US transducer is inserted, the three lights will be illuminated shortly and the self-test can be performed. After the self-test, the transducer enters normal working mode.



CAUTION

- The degree of protection provided by the transducer enclosure is IP68, but they are not allowed to be immersed in organic solvents such as alcohol.

2.3.2.2 Remote Event Marker

The remote event marker is a handheld device operated by the patient. During monitoring, press the button when a fetal movement is felt.

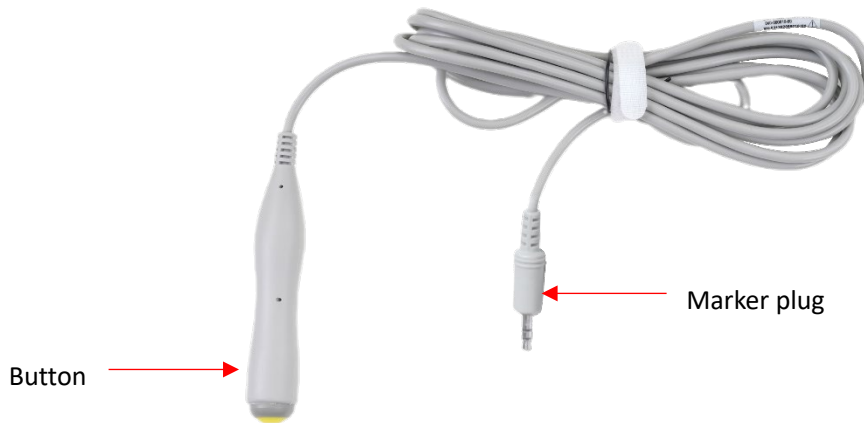

2.3.2.3 Fetal Stimulator

The fetal stimulator is used to stimulate the fetus during the ultrasound examination.

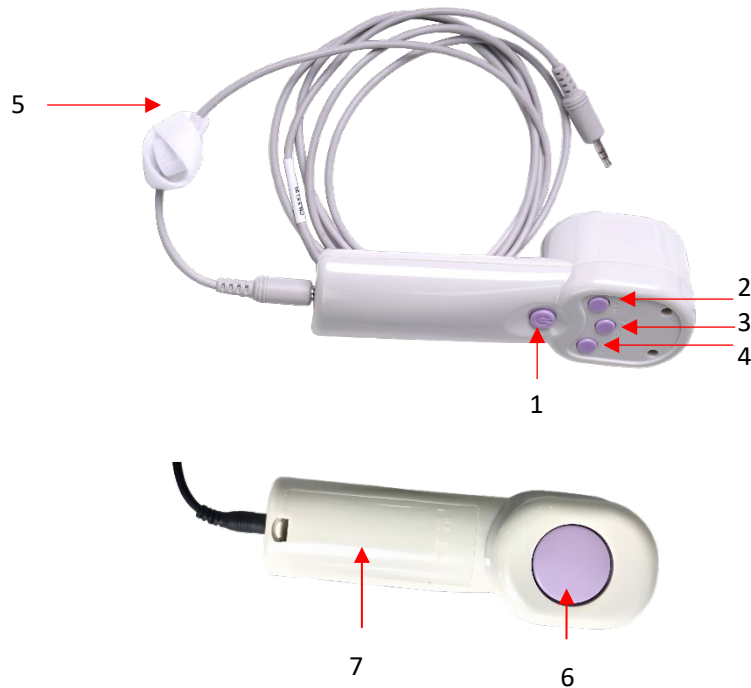

No.	Name	Description
1	ON/OFF button	Press the button to turn on/off the stimulator.
2	Fast	Press to speed up the vibration speed. The physician can adjust the speed based on the patient's conditions.
3	Speed adjustment	The vibration speed can adjusted within 3 and ∞.

4	Slow	Press to slow down the vibration speed. The physician can adjust the speed based on the patient's conditions
5	Signal cable	It is used to connect the monitor.
6	Vibration head	It is the vibration source to stimulate the fetus.
7	Battery compartment	Two AA batteries should be placed in.



NOTE

- The fetal stimulator cannot come into direct contact with the patient's skin.
- During use, the vibration head shall be wrapped with a layer of disposable medical gauze and then be firmly taped with medical tape. Do not reuse the medical gauze to avoid cross infection.
- The fetal stimulator can only be operated normally when monitoring is initiated.

Screen Display

2.4

The monitor is equipped with a touch screen. The user can conduct all the operation on the screen, except turning on/off the monitor. Patient information, alarm information, status icons, shortcut keys and parameter values are all displayed on the screen. Four main areas are introduced below.



(1) The area of patient information, alarm information and status icons

(2) Waveform area

- (3) Shortcut keys area
- (4) Parameter area

2.4.1 Patient Information, Alarm Information and Status Icons



(1) Patient information

- ◆ After admittance, the patient ID and name will be shown.
- ◆ Click the patient information area to enter the [**Patient Information**] menu to set up the brief information.

(2) Message area: displays physiological alarms, technical alarms and prompt messages.

- ◆ The messages are shown in turn based on their alarm level.

(3) Status icon area

- ◆ Network indicator

If the monitor is connected to the CMS successfully, the  symbol will be displayed; otherwise,

the  icon will be shown.

- ◆ USB drive indicator

The  icon will be shown if a recognizable USB drive is connected.

- ◆ Battery indicator: displays the current battery status and level.

- ◆ External printer indicator

The  icon will be shown if an external printer is connected properly.

(4) Time

2.4.2 Waveform Area











Waveforms are shown as trace during monitoring in the waveform area.







The background grid scale is 30-240.

The green part of the FHR waveform area represents the alarm limits the user sets (not more than 180 at the top and not less than 100 at the bottom) and indicates the normal range of a fetal heart rate.

2.4.3 Shortcut Keys

The shortcut keys are located at the bottom of the main screen and the keys displayed can be set up by the user.

Key	Name	Function	Description
	Start	Start monitoring	Press to start monitoring. Press again to stop monitoring.
 	Alarm Pause/Alarm Resume Alarm Audio Pause/Alarm Audio Resume	Pause the alarm or exit the pausing status	This key can be set as alarm pause or alarm audio pause in the [Alarm] of the [User Maintenance]. When it is set to be [Alarm Pause]: Press the key to pause alarms, and the alarm pause icon will be displayed at physiological alarm area. Press the key again to exit alarm pause. When it is set to be [Alarm Audio Pause]: Press the key to disable the alarm sound, but the alarm messages and alarm indicators will be displayed. Press the key again to exit the status.
 	Alarm off Alarm audio off	Turn off the alarm system. Turn off the alarm audio.	Alarm off: Enter [User Maintenance] → [Alarm] → [Pause/Reset] → set [Pause] to [Alarm Pause] and [Pause Time] to [Permanent]. Press the alarm off key to disable all alarms and press again to exit alarm off status. Alarm audio off: Enter [User Maintenance] → [Alarm] → [Pause/Reset] → set [Pause] to [Alarm Audio Pause] and [Pause Time] to [Permanent]. Press the alarm off key to disable all alarm audio and press again to exit alarm audio off status.
	Alarm Reset	/	Reset the current alarm system.
	TOCO Zero	Zero TOCO	Press to adjust the current TOCO value and trace to the preset baseline value.
	Record	Start/stop recording	Press this key to start or stop recording.
	Print	Start printing	Press this key to start printing.
	Channel	Switch the channel of fetal heart sound	When the monitor is turned on, the fetal heart sound comes from Channel 1 by default. If two transducers are connected, press this key to switch to Channel 2 and press again to turn back to Channel 1.

Key	Name	Function	Description
	Main Menu	Enter the setup menu	Press the key to enter the setup menu.
	Probe Off	/	When alarms, such as probe off and poor signal for transducers, are triggered, press this key to turn off the auditory and visual alarms, but these alarms will still be recorded in the alarm review.
	Paper Advance	/	Press and hold the key to advance the recorder paper.
	Event Mark	/	Press the key to mark an event during monitoring or open the list of smart notes.
	CTG Score	/	Press the key to preview the CTG score.
	Review	Enter/exit the review interface	Press the key to review the fetal monitoring information.
	Bed Transfer	Transfer the information to another device	Press the key and enter the target device number to transfer the information to the target device.

2.4.4 Fetal Monitoring Interface

During monitoring, at most 4 traces can be displayed on the screen: FHR1 trace, FHR2 trace (when monitoring twins), AFM trace and TOCO trace.

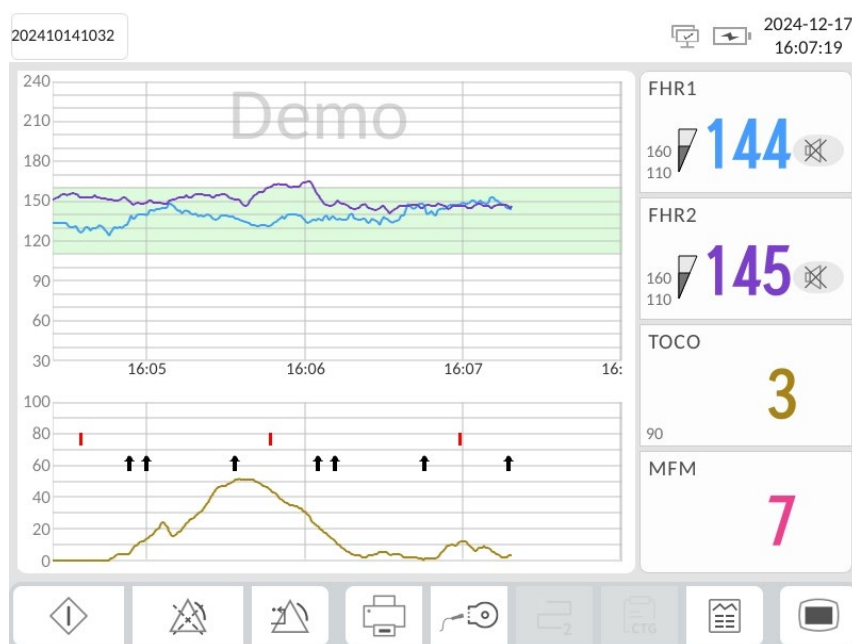

- FHR1/FHR2 Trace

The y-axis represents the FHR value, and the range is 30bpm ~ 240 bpm (American standard).

- AFM Trace/Black Mark





- AFM trace: displayed between the FHR trace and the TOCO trace, and the x-axis represents the duration of fetal movements.
- AFM black mark: displayed between the FHR trace and the TOCO trace, and the x-axis represents the duration of fetal movements.

Note: AFM trace and AFM black mark are for reference only. Please refer to the MFM marks.

- TOCO Trace

The y-axis refers to the TOCO value, and the range is 0 ~ 100.

The following symbols will be also be displayed:



Symbol	Description
	It indicates a manual fetal movement after the patient presses the remote event marker.
 (black)	It indicates an auto fetal movement and the AFM mode is set to Black Mark.
	It indicates an event is recorded, such as the patient turning around or taking injection.
	It indicates the monitor is zeroed by pressing the Zero key.
 (red)	Fetal stimulator mark

Fetal Monitoring Parameter

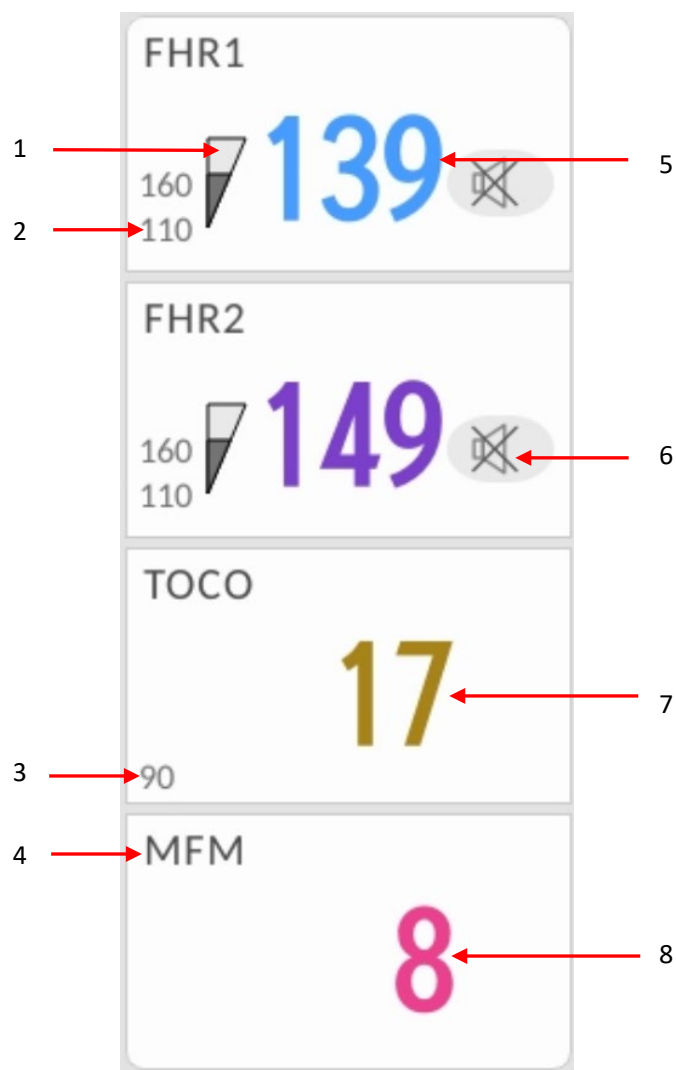
FHR1/2, TOCO value and FM value are displayed.



- | | |
|--|------------------------|
| (1) FHR signal quality. When the symbol is shown as  , it indicates the signal is poor. | (5) FHR1 value |
| (2) FHR1 alarm limit | (6) Volume setup key |
| (3) TOCO alarm upper limit | (7) Current TOCO value |
| (4) FM source: manual or auto | (8) Fetal movement |

During wireless monitoring, the screen displays the logo of the wireless US transducer and the wireless TOCO transducer, the wireless signal quality icon  and the transducer power icon . The signal quality of the wireless transducer has 4 degrees: 0, 1, 2 and 3 (when the signal strength is 0, an alarm for weak signal will be triggered). The battery of the wireless transducer has 5 degrees.

 **NOTE**

- The parameter is displayed as the same color with the corresponding waveform.

Chapter 3 Installation and Preparation



NOTE

- In order to ensure the normal operation of the device please read this Chapter and *Chapter 1 Safety* before use, and install the device as instructed herein.
- This device has not been disinfected before delivery. Be sure to clean and disinfect the device before the first use.
- The device shall be installed by authorized personnel of the company.

Installation Requirements

3.1 3.1.1 Unpacking and Checking

The monitor and the accessories ordered by the customer are shipped in boxes.

Carefully take the device and its accessories out of the packing box; keep the packaging materials safe for use in future transportation or storage. Check the accessories according to the Packing List. Check to see if there is any mechanical damage.



WARNING

- If you find any damage, contact the related hospital staff or After-sales Service Department of Comen.

3.1.2 Environmental Requirements

The operating environment for this device must conform to the environmental requirements specified in this manual.

Hostile ambient temperature may affect the precision and accuracy of the device, and cause damage to the components and circuits.

The device should reasonably avoid vibration, dust, corrosive or explosive gases, extreme temperature and humidity, etc.

When the device is installed in a cabinet, the air in the cabinet should be circulated, and there must be enough space in front and back of device for easy operation. With the cabinet door open, there should be enough space for maintenance. Leave at least 2 inches (5 cm) of space around the instrument to ensure air circulation.

During operation, it is necessary to ensure that the device is free from condensation. Condensation may form as the instrument is moved from one room to another. This is because the instrument is exposed to moist air

and different temperatures. To avoid unnecessary troubles, if condensation occurs, leave the instrument dry before use.



NOTE

- **Condensation means gas or liquid condenses when it cools. For example, water vapor is changed into water when it cools, and the water is changed into ice when it cools. The lower the temperature, the faster the condensation goes.**

Installation of the Battery

3.2



WARNING

- **Use only the batteries specified by the manufacturer.**
- **Do not remove the battery during monitoring.**
- **The installation and replacement of the battery shall be performed by trained personnel.**
- **The monitor must be turned off and disconnected from the AC power before installing or removing the battery.**

Carry out the following steps to install or remove the battery:

Install the battery::

- 1) Make sure the monitor is powered off and disconnect the power cord and other connection wires.
- 2) Put the monitor on a clean, flat surface with its screen downwards.
- 3) Remove the locking screws from the battery compartment cover with a screwdriver to remove the cover.
- 4) Take the battery out from the packaging and insert it into the battery compartment with the label facing upwards.
- 5) Insert the plug of the battery into the socket and place the battery into the battery compartment.
- 6) Put the battery compartment cover back and fix the screws.

Remove the battery:

- 3.3 The procedure for removing the battery from the monitor is opposite to that for installing the battery.

Note: Before turning the monitor upside down, fold the display screen flat.

Installation of the Monitor

The monitor can be placed on a flat surface, or mounted on a wall or a trolley. Contact Comen's after-sales service for installation or refer to provided operating instructions if required.

**CAUTION**

- If the monitor is required to be mounted on a wall, the user shall be responsible for the structural integrity and solidity of the wall and for the compliance with local regulations. The manufacturer shall not be responsible for damages resulting from incorrect installation.

Installation of Recorder Paper

3.4

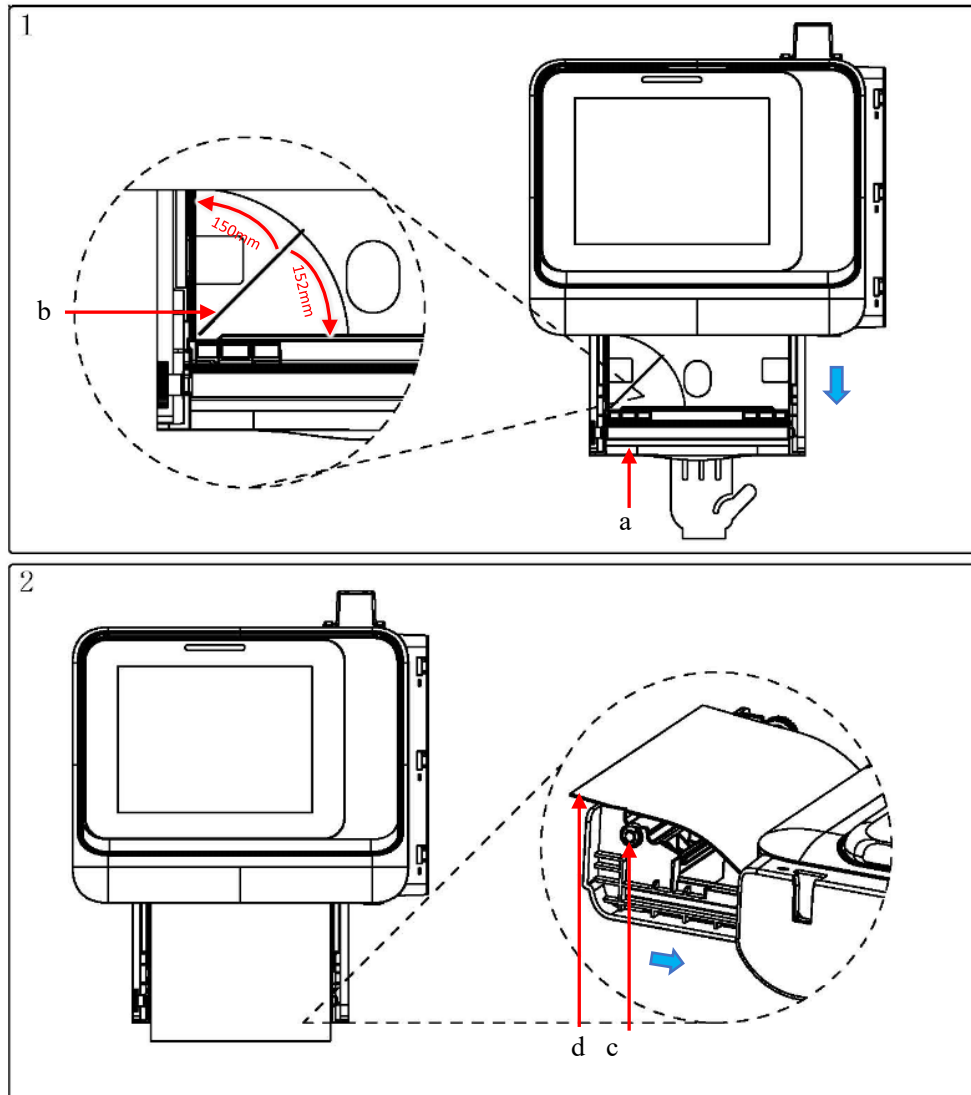

- 1) Pull out the paper compartment with the thumb against the device and the other four fingers in the groove (as shown in 1a).
- 2) Adjust the position of the plate (1b) according to the size of the recorder paper:
 - If the paper is 150mm wide, place the plate vertically.
 - If the paper is 152mm wide, place the plate horizontally.
- 3) Put the recorder paper into the compartment. The pane should face upwards and the FHR trace area should be on the left.

- 4) Pull out a sheet of paper cross the roller (2c) and the paper should extend out of the edge of the door (as shown in 2d).
- 5) Make sure the recorder paper is placed flat and push the paper compartment back until it is locked.



WARNING

- Use only the recorder paper supplied or recommended by the manufacturer. The use of paper not approved by Comen may reduce the functionality of the device and the performance of the system.
- The plate should be placed in accordance with the recorder paper size and the recorder paper configured in the monitor.



CAUTION

- Load the recorder paper carefully; otherwise the thermal print head may get damaged.
- During output by the recorder, it is not allowed to pull the record paper outward with force; otherwise the recorder may get damaged.
- Do not keep the recorder door open except for paper change or troubleshooting.

3.5 Adjusting the Screen

Flip the screen as shown below (rotation range: 0°~60°).

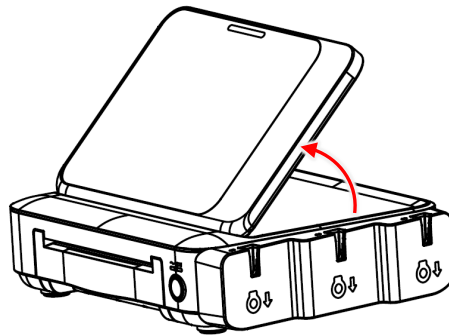

3.6

Connection of the AC Power Supply

Before connecting to the AC power supply, verify that the voltage and frequency of the AC power supply conform to the requirements specified in this manual.

Carry out the following steps to connect the AC power supply:

- 1) Use the power cord provided with the monitor, and connect one end of the power cord to the monitor's power connector.
- 2) Plug the other end of the power cord into a grounded AC power outlet.

- 3) Make sure the AC power indicator is illuminated, which indicates the normal connection to the AC power.

**WARNING**

- If there is any doubt about the protective grounding wire of the external power in terms of the completion of installation or wiring, the monitor should be powered by the internal power supply.

**NOTE**

- Only connect the power cord to a specific hospital AC power outlet.
- When a battery is provided, the battery must be charged after transport or storage. If the battery is low and the AC power is not connected, the monitor may fail to work. Once the monitor is connected to an AC power supply, the battery will be charged whether the monitor is switched on or not.
- Do not use AC power extension cords or a mobile multiple socket-outlet.
- Do not modify the electrical plugs to accommodate an ungrounded electrical socket.

Equipotential Grounding

3.7

The monitor must be connected to a power outlet with protective grounding. For cardiac or cerebral examinations, the monitor must be connected to a standalone equipotential grounding system. Connect one end of the equipotential conductor (potential equalization conductor) to the equipotential connector on the rear panel of the monitor and the other end to a connector of the equipotential grounding system. In the event the protective grounding system is damaged, the equipotential grounding system serves as the safety function of the protective grounding wire.

Cardiac (or cerebral) examination can only be performed in a room installed with a protective grounding system. Before each use, ensure the monitor is in a normal operating status.

**NOTE**

3.8

- If the use of the device is affected by the equipotential grounding, contact the Company's After-Sales Service Department or agents.

Connection of Accessories

- Connecting to the device:
 - Wireless transducers: When the monitor is turned on, remove the transducers from the charging station. If the transducer is connected with the monitor, the beside monitor number and symbol will

be shown on the display of the transducer.

- Wired transducers: Connect the plug of the transducer to the connector on the monitor.
- Placing on the patient:
 - Place the required accessories on the patient following the steps in related chapters.

Start-up and Shutdown

3.9.1 Start-up

3.9

Press the ON/OFF button on the front panel of the monitor to switch on the device, and the power-on indicator lights up. After it is turned on, the device performs a self-test. The alarm indicator lights up in red and yellow in turn. The company logo will be displayed on the screen with a “beep” sound and the main screen is displayed.



WARNING

- If there is any evidence of failure or any error messages are displayed, do not use this monitor. Contact a service technician of Comen or an electrical engineer in your hospital.



NOTE

- If an error is found during self-test, an alarm will be generated. After shut-down, wait for at least 1 minute before restarting the monitor.

3.9.2 Shutdown

1. Confirm that it is safe for the device to be stopped.
2. Disconnect all the device cables and sensors from the patient.
3. Save or clear patient data as required.
4. Press the ON/OFF button for 3s to turn off the monitor. To completely disconnect the power supply, please remove the power cord plug from the AC power supply.



CAUTION

- If the monitor cannot be turned off normally, press and hold the ON/OFF button for 10 seconds to force the device to turn off, but a forced shutdown may cause data loss.

Main Menu



Click the  button to enter the main menu. Select each function button and set up the device in the submenu as required. If no operation is conducted on the main menu or the submenu for 60s, the system will return to the main screen.

- Close the page/Back to the previous page: Click [**Close**] in the submenu to close the menu page. Press  to return to the previous page.

System Setup

Volume, screen brightness, unit, module color, screen color, night mode and custom shortcuts can be set up in the [**System Setup**] page.

4.2.1 Volume



- 1) Select the shortcut of main menu.
- 2) Select [**System Setup**] → [**Key Volume**], [**Reminder Volume**] or [**Alarm Volume**].
- 3) Press  or  to increase or decrease the volume.



WARNING

- Do not rely only on the audible alarm. Otherwise, patient safety may be at risk if the alarm volume is low. Pay close attention to the patient's actual clinical conditions.

4.2.2 Screen Brightness

- 1) Select the shortcut of main menu.
- 2) Select [**System Setup**] → [**Brightness**].
- 3) Press  or  button to decrease or increase the screen brightness.

4.2.3 Units

- 1) Select the shortcut of main menu.

- 2) Select [**System Setup**] → [**Height Unit**], [**Weight Unit**]
- 3) Set the units to: cm (default value) or inch, kg (default value) or lb.

4.2.4 Screen Color

The screen color of the device can be set up as required:

- 1) Select the shortcut of main menu.
- 2) Select [**System Setup**] → [**Screen Color**].
- 3) Select the desired color. Reboot the device to activate the selected color.

4.2.5 Module Color

The operator can set the color of parameter modules and the corresponding waveforms as required:

- 1) Select the shortcut of main menu.
- 2) Select [**System Setup**] → [**Module Color**].
- 3) Select the desired color.

4.2.6 Night Mode

Refer to **Section 4.4.2 Night Mode** for more information on night mode.

4.2.7 Custom Shortcuts

The shortcut keys shown at the bottom of the main screen can be set up by the operator as follows:

- 1) Select the shortcut of main menu.
- 2) Select [**System Setup**] → [**Custom Shortcuts**].
- 3) Click the shortcut keys in the area A to select the shortcut to be replaced, and then select the shortcut in the area B to replace the shortcut key shown on the main screen.
 - Area A: displays the shortcut keys shown on the main screen, in which the keys in light grey cannot be changed by default.
 - Area B: displays the shortcut keys not shown on the main screen.



User Maintenance

4.3.1 Date and Time

4.3 If the monitor is connected with the Central Monitoring System (CMS), the system time of the monitor synchronizes with the CMS and cannot be set up by the user.

Follow the steps below:

- 1) Select the shortcut of main menu → **[Maintenance]** → enter the maintenance password.
- 2) Select **[Date and Time]** to set up date and time.
- 3) Set up **[Date Format]**.
- 4) If the 12-hour time format is required, turn off **[24-Hour Time]**.

4.3.2 Alarm

Refer to **Section 6.7 Alarm Setup** for more information.

4.3.3 Configuration Management

Load the default configuration to restore the defaults. The default configuration includes the configuration of the parameter modules, fetal setup, system setup, print setup, user maintenance (including alarm, module, language, scanner and patient information management) and the configuration in starting monitoring.

- 1) Select the shortcut of main menu → **[Maintenance]** → enter the maintenance password.
- 2) Select **[Config. Management]** → press **[Load]**.
- 3) Select **[OK]** in the displayed dialog to restore the configuration to the default.

4.3.4 Network Setup

4.3.4.1 Network Protocol & Network Type

- 1) Select the shortcut of main menu → **[Maintenance]** → enter the maintenance password.
- 2) Select **[Network Setup]** → **[Network Protocol]**, **[Network Type]**
 - Network Protocol: The CMS protocol is set by default.
 - Network Type: Wired network is set by default.

4.3.4.2 Wired Network

- 1) Select the shortcut of main menu → **[Maintenance]** → enter the maintenance password.
- 2) Select **[Network Setup]** → **[Wired Network]**
 - The IP address can be input automatically or manually:



Automatic input: turn on the switch of the automatic IP acquisition and the device will acquire the IP address automatically.

Manual input: turn off the switch, and input the correct value of IP address, subnet mask and gateway.

- **MAC Address:** If MAC address is to be modified, enable the [**Modify MAC Address**] and then input the MAC address.

4.3.4.3 Connection to Obstetric Central Monitoring System

The monitor can be connected to the central monitoring system of the company via network setup. Follow the steps below:

- 1) Select the shortcut of main menu → [**Maintenance**] → enter the maintenance password.
- 2) Select [**Network Setup**] → [**OB**] (Obstetric Central Management System)
 - **Network Bed No.:** press [**Network Bed No.**] and input a valid net bed number (1-254).
 - **Server IP:** Input the IP address of the monitoring system. This IP address must be in the same network segment as the IP address of the monitor.
 - **Server Port:** Set the [**Modify Server Port**] to be on and then enter the server port.
 - **Auto Admit Patient:** turn the [**Auto Admit Patient**] on or off.
 - **ON:** The monitoring system will automatically connects to the monitor and display the patient information regardless of whether the device is monitoring a patient.
 - **OFF:** The monitoring system only displays the patient information when the device starts to monitor a patient.
 - **Connect to the Old CMS:** turn on the [**Connect to the Old CMS**] switch and the device will be connected to another central monitoring system.
- 3) View the symbol of the network connection:
 - When  is displayed, the monitor has been successfully connected to the monitoring system.
 - When  is displayed, the monitor fails to connect to the monitoring system. Check the information entered and if there is still any doubt, please contact the after-sales department of Comen.



NOTE

- **The Network bed number must be unique in the central monitoring system.**
- **For details, see the user manual of Obstetric Central Monitoring System.**
- **After the monitor is connected to the system, [Date and Time] turns grey and cannot be set up.**
- **If device failure occurs due to network bed number conflict, disconnect the network cable, reboot the monitor and reset the network and the network bed number.**

- If the device is connected to the monitoring system through wired network, the maximum alarm delay time is less than 2s. The maximum alarm delay time is less than 5s for wireless connection.

4.3.4.4 HL7 Setup

- 1) Select the shortcut of main menu → **[Maintenance]** → enter the maintenance password.
- 2) Select **[Network Setup]** → **[HL7 Setup]** and set the values as required.

4.3.4.5 DICOM Setup

DICOM (Digital Imaging and Communication of Medicine) is a standard for the storage and transmission of medical images. Follow the steps below:

- 1) Select the shortcut of main menu → **[Maintenance]** → enter the maintenance password.
- 2) Select **[Network Setup]** → **[DICOM Setup]** and set the values as required.

4.3.5 Language Setup

- 1) Select the shortcut of main menu → **[Maintenance]** → enter the maintenance password.
- 2) Click **[Language Setup]** → select the required language.

Reboot the monitor to activate the selected language.

4.3.6 Version

View the version information as follows:

- 1) Select the shortcut of main menu → **[Maintenance]** → enter the maintenance password.
- 2) Select **[Version]** to view the version of the device.

4.3.7 Battery Information

Refer to **Section 10.2 Viewing Battery Information** for details.

4.3.8 Scanner Setup

The barcode information obtained by the scanner can be automatically added to the patient information (patient ID or registration No.).

- 1) Select the shortcut of main menu → **[Maintenance]** → enter the maintenance password.
- 2) Select **[Scanner Setup]** to fill the information to patient ID or registration number.

4.3.9 Print Setup

The line width for the internal recorder can be set up as follows.

- 1) Select the  shortcut key → **[Maintenance]** → enter the maintenance password.
- 2) Select **[Print Setup]** and set up the line width of FHR1/FHR2/AFM/TOCO as required.

4.3.10 Monitor Location

In **[Monitor Location]**, the device information and location can be set up as follows:

- 1) Select the shortcut of main menu → **[Maintenance]** → enter the maintenance password.
- 2) Select **[Monitor Location]**:
 - Device information
 - Device ID: view the device ID.
 - Monitor Name, facility, department: enter the corresponding information in respective item.
 - LAN MAC: view the LAN MAC address.
 - Device location: the user can select the location to be fixed or not fixed.
 - **[Fixed]**: input the information of **[Bed No.]** and **[Room No.]** and the information will be synchronized to the patient information.
 - **[Unfixed]**: **[Bed No.]** and **[Room No.]** can be entered and modified in **[Patient Information]**.



NOTE

- The character limit of **[Monitor Name]**, **[Facility]**, **[Department]**, **[Bed No.]** and **[Room No.]** is respectively 24, 18, 24, 15 and 15.
- For the monitor information:
 - If **[Fixed]** is selected, make sure the monitor location is the same as the actual location.
 - If **[Unfixed]** is selected, after each discharge of a patient, reenter the bed number and room number.
- **[Bed No.]** and **[Room No.]** can only be shown in the **[Patient Information]** when they are selected in **[Patient Info Manage]** page.

4.3.11 Demo Mode

Refer to **Section 4.4.3 Demo Mode** for details.

4.3.12 Patient Information Management

The information shown in the **[Patient Information]** can be set up in **[Patient Info Manage]** as follows:

- 1) Select the shortcut of main menu → **[Maintenance]** → enter the maintenance password.
- 2) Click **[Patient Info Manage]**:
 - Select the items as required.
 - If **[Custom 1/2]** is to be added, select the corresponding item and enter the information required.

**NOTE**

- The character limit of [Custom 1/2] is 15.

4.3.13 Patient File Management

The patient file information can be viewed or deleted in the [Patient File Manage] page.

- 1) Select the shortcut of main menu → [Maintenance] → enter the maintenance password.
- 2) Select [Patient File Manage] → [Patient Files]:
 - Delete a patient file: After the selection of a patient file, click the [Delete] button and choose [OK] in the displayed dialog to delete the patient file.

Work Modes**4.4 4.4.1 Monitoring Mode**

Patient monitoring can be conducted in the monitoring mode, and the monitor is in monitoring mode automatically after the device is turned on.

4.4.2 Night Mode

Night mode is provided to avoid disturbing the patient at night. After exiting the night mode, the monitor will revert to the settings before entering the night mode.

Activate the night mode as follows:

- 1) Select the shortcut of main menu → [System Setup] → [Night Mode].
- 2) Set the settings in the night mode → [Enter Night Mode].

**CAUTION**

- Before entering night mode, adjust the screen brightness, alarm volume and key volume to an appropriate level to avoid potential risks.

Exit night mode:

Select the shortcut of main menu → [System Setup] → select [Exit Night Mode].

**NOTE**

- If the monitor is connected to the CMS before entering the night mode, the monitor exits night mode automatically after it is disconnected from the CMS.

4.4.3 Demo mode

Enter the demo mode as follows:

Select the shortcut of main menu → **[Maintenance]** → enter the password → turn on or off **[Demo Mode]**.



WARNING

- **Demo waveforms are used to simulate the actual monitoring process. Demo mode can only be used to demonstrate the monitor performance and assist in training courses. In actual clinical use it is NOT recommended to use the demo mode, because the users/operators may mistake the demo data for waveforms and patient parameters which can put patient safety at risk.**

Safety Information



WARNING

5.1

- Before using the monitor for fetal monitoring, fetal life should be confirmed by other means, such as using a fetoscope, stethoscope, Pinard stethoscope or obstetric ultrasound.
- The device is only intended for use in the prenatal examination room, labor room or delivery room. It cannot be used in ICU, in operating room or at home.
- Do not use the monitor during the use of electrosurgical equipment (including high frequency surgical equipment) or during MRI examinations to avoid personal injury.
- Verify the alarm settings before patient monitoring to ensure that the settings suit the current patient.
- If the monitoring is required to be conducted for a long period, change the position of the transducer at least every 30minutes. Change the transducer position immediately when the skin quality of the patient decreases.

5.2

Confirming Fetal Life

The fetal heart rate signal may not be distinguished from the maternal heart rate at all times.

- Signal sources that might be mistaken as the FHR signal:
 - Maternal heart rate(MHR) higher than normal range
 - Signals from maternal heart, aorta or other large vessels
 - Electrical impulses of the maternal heart transmitted from a recently deceased fetus
- Signal sources that might be mistaken as fetal movement signal:
 - Change of the ultrasound transducer position
 - Movement of a deceased fetus during or after the palpation
 - Movement of a deceased fetus during or after maternal movement



5.3

Fetal Setup

5.3.1 Fetal Movement Volume

A reminder tone will be generated when the button of the event marker is pressed. Adjust the volume as

follows:

- 1) Select the  shortcut key → **[Fetal Setup]** → **[FM Volume]**.
- 2) Press  or  to increase or decrease the volume.

5.3.2 UA Baseline Setup

When a TOCO transducer is connected to the monitor, press the  symbol on the main screen and the TOCO will zero based on the value set in the **[UA Baseline]**.

- 1) Follow one of the two ways to enter **[UA Baseline]**:
 - Select the TOCO parameter area to enter **[TOCO Setup]**.
 - Select the  shortcut key → **[Fetal Setup]**.
- 2) Set up the TOCO value: 0, 5, 10 (the default value), 15 or 20.



NOTE

- If the value of **[UA Baseline]** is set up when a TOCO transducer is connected, the value will be changed and the TOCO will be zeroed to the set value.

5.3.3 AFM Setup

Auto fetal movement (AFM) or manual fetal movement (MFM) can be set as required.

- 1) Follow one of the two ways to enter **[FM Source]**:
 - Select the AFM/MFM parameter area to enter **[FM Setup]** → **[AFM]**.
 - Select the  shortcut key → **[Fetal Setup]** → **[AFM]**.
- 2) Set the **[AFM]** to be on or off.
 - If **[AFM]** is turned on, **[FM Source]** can be set to **[Manual]** or **[Auto]** and **[AFM Mode]** can also be set.
 - If **[AFM]** is turned off, only manual fetal movement is available.



NOTE

- If the **[AFM]** is turned off, or during printing, **[FM Source]** and **[AFM Mode]** cannot be set up.

5.3.4 FM Source

The source of fetal movement can be selected as required.

- 1) Follow one of the two ways to enter **[FM Source]**:
 - Select the AFM/MFM parameter area to enter **[FM Setup]**.

- Select the  shortcut key → **[Fetal Setup]**.
- 2) Select the source of fetal movement: **[Manual]** or **[Auto]** (the default setup)
 - Auto (AFM): The device counts the fetal movement based on the amplitude and frequency.
 - Manual (MFM): The patient presses the event marker to count the fetal movement.

**NOTE**

- The parameter area will display the same source set up in the **[FM Source]**.



5.3.5 AFM Mode

The device indicates the results of AFM in the form of trace or black mark.

- 1) Follow one of the two ways to enter **[AFM Mode]**:
 - Select the AFM/MFM parameter area to enter **[FM Setup]**
 - Select the  shortcut key → **[Fetal Setup]**
- 2) Select the AFM mode: **[Trace]** (the default setup) or **[Black Mark]**

5.3.6 Smart Note

Significant events can be marked during monitoring. Follow the steps below:

- 1) Select the  shortcut key → **[Fetal Setup]** → **[Smart Note]**.
- 2) Turn on or off the smart note.
 - If **[Smart Note]** is turned on: press the  button and a black downward arrow will be shown above the TOCO waveform.
 - If **[Smart Note]** is turned off: press the  button and a **[Smart Note]** chart will be displayed. Select an event type and then choose a specific event. A letter will be shown above the TOCO waveform based on the event type the user selects: A: DRUGS, B: POSITION, C: MEMBRANES, D: PROCEDURES, E: OTHER, F: ANTENATAL, G: REASON.

5.3.7 CTG Score

Refer to **Chapter 9 CTG Score**.

5.3.8 Cross Duration and Cross Error

During monitoring, if the difference between FHR1 and FHR2 is less than or equal to the value set in **[Cross Error]**, and simultaneously these two waveforms cross for a time longer than the value set in **[Cross Duration]**, a high-level alarm will be generated. Adjust the position of the US transducer immediately.

Follow the steps below to set the value:

- 1) Select the  shortcut key → [Fetal Setup].
- 2) Set [Cross Duration]: OFF, 30s (default), 35s, 40s, 45s, 50s, 55s, 60s, 90s and 120s.
- 3) Set [Cross Error]: 0bpm, 1bpm, 2bpm, 3bpm, 4bpm and 5bpm (default).







NOTE

- If [Cross Duration] is set to be [OFF], the alarm can only be generated based on the [Cross Error]. The alarm may be ineffective or invalid. Therefore, the operator shall operate with caution.

Monitoring Setup

5.4.4.1 Fetal Volume

Follow one of the two ways to set the fetal volume.

- 1) Click the  button in the FHR1/FHR2 parameter area, and then select the corresponding volume level.
- 2) Select the  shortcut key → [Monitoring] → [Fetal Volume] → press  or  to increase or decrease the volume.

5.4.2 Auto Print

See *Section 8.6.3 Start Recording Automatically* for more information.

5.4.3 Patient Information Setup

If the [Patient Information] of the [Monitoring] is turned on, press  to start monitoring and the [Patient Information] will be displayed. The user should input the information of the current patient before starting monitoring.

- 5.5 1) Select the  shortcut key → [Monitoring] → [Patient Information].
- 2) Set it to be on or be off (default).

FHR1/2 Setup

5.5.1 Alarm Switch

Before each monitoring, adjust the alarm settings to be appropriate for the current patient.

If the alarm switch of fetal monitoring is turned off, no audio alarm or alarm message will be generated.

Refer to **Section 6.4 Parameter Alarm ON/OFF** for details.

5.5.2 Alarm Level

Refer to **Section 6.5.1 Set Alarm Level** for details.

5.5.3 Alarm Limit

Refer to **Section 6.6 Set Alarm Limit** for details.



NOTE

- If the [Alarm Limit] is changed in [FHR1 Setup], the alarm limit of FHR2 will be changed accordingly and vice versa. The upper and lower limit of the green area in the FHR waveform area is determined by FHR alarm limit settings.

5.5.4 Upper/Lower Limit Alarm Delay

The alarm delay is the time from the occurrence of measured value exceeding the alarm limits to when an alarm is triggered. The time can be set up in [Upper Limit Alarm Delay] and [Lower Limit Alarm Delay].

- 1) Select the FHR1/FHR2 parameter area to enter the corresponding setup page.
- 2) Set the upper/lower limit alarm delay:
 - Upper limit alarm delay: select the delay time from when the measured value is beyond the upper limit to when the alarm is triggered. You can set the [Upper Limit Alarm Delay] to 0s, 5s, 10s, 15s or 20s.
 - Lower limit alarm delay: select the delay time from when the measured value is lower than the limit to when the alarm is triggered. You can set the [Lower Limit Alarm Delay] to 0s, 5s, 10s, 15s or 20s.

5.5.5 Weak Signal Alarm

During monitoring, if the signal quality of the wireless transducer of FHR1/2 is 0 but the measured value is not the same, the user can define whether a high-level alarm can be generated.

- 1) Select the FHR1/FHR2 parameter area to enter the corresponding setup page.
- 2) Set [Signal Alarm Switch] to be on (default) or off:
 - On: when the signal quality of FHR1/2 is 0 but the measured value is not the same, an alarm will be generated to adjust the distance between the monitor and the patient.
 - Off: no alarm will be generated in the event of poor signal.

**NOTE**

- If the [Weak Signal Alarm] is turned on or off in [FHR1 Setup], the corresponding settings in FHR2 will be changed accordingly and vice versa.

TOCO Setup

See *Chapter 6 Alarms* for more information on the setup of TOCO alarms.

5.6 For the setup in [UA Baseline], refer to *Section 5.3.2 UA Baseline Setup*.

FM Setup

5.7 Refer to *Section 5.3 Fetal Setup* for more information on the auto fetal movement and manual fetal movement.

FHR Monitoring

5.8

The high sensitivity ultrasound transducers, high performance signal processing circuit and advanced calculation define the accuracy and reliability of monitoring fetal heart rate.

Place the ultrasound transducer on the patient's abdomen and it emits a low-energy ultrasound signal to the fetal heart and detects the reflected signal. Then the fetal heart rate will be obtained. It is recommended to use ultrasound for fetal heart monitoring after 24 weeks of pregnancy.

**WARNING**

- Before monitoring, check the position where the transducer is placed. Change the transducer position immediately if the skin is in poor condition, especially if there is injury or allergy.
- Before using the monitor for fetal monitoring, fetal life should be confirmed by other means, such as using a fetoscope or stethoscope.
- Place the transducer in the optimal position for quality records. Never place the transducer where strong placental sound or umbilical cord blood sound can be noticed. Start monitoring only when a clear fetal heart signal can be detected.
- Do not start wireless monitoring until the wireless transducer is connected to the monitor successfully and the device number and icon are displayed on the screen of the transducer.
- If the FHR drops by or more than 10 bpm, or if its rhythm slows suddenly, check if the maternal heart rate is being monitored. If so, reposition the transducer for a clear fetal heart signal.
- If the fetal heart rate suddenly drops by 10 bpm or more, or if the fetal heart rhythm suddenly slows, check that the ultrasound probe is capturing the mother's heart rate rather than the fetal heart rate. If so, reposition the ultrasound probe and ensure that the probe obtains a clear fetal heart sound.

- In the second trimester (from week 24 to week 28), the fetus has a greater activity. Reposition the transducer if the fetal heart moves away from it.
- If the monitoring is required to be conducted for a long period, change the position of the transducer at least every 30minutes. Change the transducer position immediately when the skin quality of the patient decreases.
- During ultrasound fetal monitoring, if ultrasound imaging, Doppler flow measurement or monitoring with ultrasound monitoring of other manufactures is conducted, FHR readings may not be accurate and the trace recoding may be detorted.
- Maternal activity during labor may affect FHR calculations.

**CAUTION**

- Do not mistake high maternal heart rate signal as fetal heart rate. To distinguish it from fetal hear rate, the maternal heart rate or pulse is recommended to be monitored at the same time.
- Unexpected intermittent FHR readings may be measured if the US transducer is connected to the device but not applied to the patient.
- Compared with inpatient monitoring, in outpatient monitoring, signal loss may occur and maternal heart rate may be detected. The frequency of the patient's walk may be detected and mistaken as the FHR signal.
- Do not mistake the maternal movement as the fetal movement.
- It is recommended to start printing FHR trace when a clear fetal heart signal is detected and FHR computing is stable.
- If AFM is enabled, the transducer should be fixed with a belt and maternal movement should be reduced.
- Use coupling gel qualified for medical devices.

5.8.1 Testing Ultrasound Transducers

Follow the steps below to test the ultrasound transducer:

- 1) Turn on the monitor.
- 2) Connect the transducer to the monitor.
- 3) Select the fetal heart sound for the channel.
- 4) Adjust the volume to an appropriate level.
- 5) Hold the transducer in one hand and the other hand taps the back of the hand as indicated below.



6) Check if there is noise. If noise is heard, it indicates the transducer works properly.

If the testing of one ultrasound transducer fails, perform the same test again on another transducer. If the second transducer passes the test, it indicates that the first one has malfunctioned. If the second one also fails, contact the manufacturer for repair.

5.8.2 FHR Monitoring with Ultrasound

5.8.2.1 Preparation

1. Prepare the accessories required: wired/wireless US transducer, coupling gel and belt.
2. Make sure that the US transducer works properly. Refer to **Section 5.8.1 Testing Ultrasound Transducers** for more information.
3. Make sure the current fetal monitoring settings are applicable to the current patient. Refer to **Section 5.3 Fetal Setup** and **Section 5.5 FHR1/2 Setup** for more information.

5.8.2.2 Fixing the US Transducer on the Patient

1. Placement of the belt
 - Supine position: Place the belt across the upper center of the bed. Lay the patient on the bed and make sure the belt will be around the patient's abdomen when it is fastened. Or,
 - Semi-recumbent position: Fix the belt around the patient's abdomen.
2. Determining the transducer position
 - Carefully observe the patient's abdomen and use Leopold's maneuvers to assess fetal position.
 - Search for a position where good fetal heart signals can be obtained with a stethoscope or fetal Doppler.
For cephalic presentation, search the fetal heart below the umbilicus and place the transducer above the umbilicus for breech presentation.
 - The fetal heart signal will move downward in the process of labor, during which the fetal heart sound should be paid attention to and move the transducer accordingly.
3. Obtaining the fetal heart signal

Apply a thin layer of coupling gel to the transducer and turn up the fetal sound of the monitor. Move the

transducer in a circular motion and simultaneously observe the fetal heart signal quality and FHR value to search for a good and stable fetal heart signal. When a good signal is received, place the transducer securely and adjust the volume to a clearly audible level.

Note that extra gel should be applied to the transducer to ensure good contact with the patient's skin if the transducer does not move smoothly or during long-time monitoring.

4. Securing the transducer

Fix the transducer with the belt to obtain the stable and optimal fetal heart signal and ensure that the belt is securely yet comfortably attached to the patient.

5. Confirmation of fetal heart signal source

As it is possible to mistake the maternal heart rate signal as the fetal heart rate signal, it is necessary to confirm that the signal detected is from the fetal heart. One of the following methods can be performed:

- Search for the fetal heart with the fetal Doppler before monitoring.
- Monitor the maternal pulse with a stethoscope and check if it is changing with the fetal heart rate.

If the maternal heart rate signal is mistaken as the FHR signal, reposition the transducer.



NOTE

- **It is recommended to monitor the maternal heart rate at the same time to avoid misidentification of higher maternal heart rate as fetal heart rate.**
- **Place the transducer at the position where an optimal fetal heart signal can be received.**
- **During long-time monitoring, hypotension may occur. Pay close attention to the patient to avoid possible injury caused by orthostatic hypotension.**
- **Compared with supine position, semi-recumbent position or lateral position are suggested for the patient during monitoring to ensure better blood circulation of the uterus.**
- **Extra gel should be applied to the transducer to ensure good contact with the patient's skin if the transducer does not move smoothly or during long-time monitoring.**
- **After the transducer is placed on a patient, its temperature may slightly rise (not more than 10°C above the ambient temperature). If it is not applied to a patient, its temperature may also slightly rise (not more than 10°C above the ambient temperature).**
- **Possible intermittent FHR readings may be measured if the US transducer is connected to the device but not applied to the patient.**

5.8.3 Monitoring Twin FHRs with Ultrasound

5.8.3.1 Operation Steps

When monitoring twins, two US transducers are required to connect to the monitor. Follow the steps in **Section 5.8.2 FHR Monitoring with Ultrasound** to monitor twin FHRs, and press the Channel shortcut key to switch the channel of fetal heart sound between Channel 1 and Channel 2.

When both US transducers are positioned, make sure that clear fetal heart sound can be heard from both channels and the two FHR traces and values are displayed on the screen.

5.8.3.2 Signals Overlap Verification (SOV)

During twin FHR monitoring, one FHR signal may be mistaken as the other FHR signal. The signals overlap verification (SOV) function can reduce this.

During monitoring, if overlapping is detected, **[Adjust Transducer Position]** will be displayed. At this moment, check the patient's condition or adjust the transducer until the other FHR is detected.

5.8.3.3 FHR2 Offset

An offset for FHR2 trace of -20bpm or +20bpm is provided to distinguish the trace of FHR1 and FHR2. Follow the steps below to set up FHR2 Offset:

- 1) Select the  shortcut key → **[Print Setup]** → **[Record Setup]** → **[FHR2 Offset]**.
- 2) Select **[0 bpm]** (default), **[+20 bpm]** or **[-20 bpm]**:
 - -20 bpm: the FHR2 trace is 20bpm lower than the actual value.
 - 0 bpm: the FHR2 trace is at the actual position.
 - +20 bpm: the FHR2 trace is 20bpm higher than the actual value.

5.9

TOCO Monitoring



WARNING

- Before monitoring, check the position where the transducer is placed. Change the transducer position immediately if the skin is in poor condition, especially if there is injury or allergy.
- Do not start wireless monitoring until the wireless transducer is connected to the monitor successfully and the device number and other icons are displayed on the screen of the transducer.
- If the monitoring is required to be conducted for a long period, change the position of the transducer at least every 30minutes. Change the transducer position immediately when the skin quality of the patient decreases.

5.9.1 Testing TOCO Transducers

Test the TOCO transducer as follows:

- 1) Turn on the monitor.
- 2) Connect the TOCO transducer to the monitor.
- 3) Gently press the center of the transducer (as shown below).

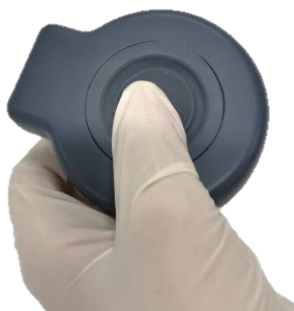

- 4) Check if the TOCO value on the display shows the change.

If the testing of one TOCO transducer fails, perform the same test again on another transducer. If the second transducer passes the test, it indicates that the first one has malfunctioned. If the second one also fails, contact the manufacturer for repair.

5.9.2 TOCO Monitoring with a TOCO Transducer

5.9.2.1 Preparation

1. Prepare the accessories required: wired/wireless TOCO transducer and belt.
2. Make sure that the TOCO transducer works properly. Refer to **Section 5.9.1 Testing TOCO Transducers** for more information.
3. Make sure the current TOCO monitoring settings are applicable to the current patient. Refer to **Section 5.3 Fetal Setup** and **Section 5.6 TOCO Setup** for more information.

5.9.2.2 Fixing the TOCO Transducer on the Patient

1. Placement of the belt
 - Supine position: Place the belt across the upper center of the bed. Lay the patient on the bed and make sure the belt will be around the patient's abdomen when it is fastened. Or,
 - Semi-recumbent position: Fix the belt around the patient's abdomen.
2. Securing the transducer
 - a) Set the correct UA Baseline.
 - b) Place the TOCO transducer on the flat part of the patient's abdomen about 3cm above the fundus.
 - c) Wrap the belt around patient's abdomen and fix the transducer by its buckle through the overlapped part on the belt.
 - d) Ensure that the belt is securely yet comfortably attached to the patient.
3. Zeroing TOCO

Press the TOCO Zero shortcut key on the main screen to zero TOCO, but not during a contraction.

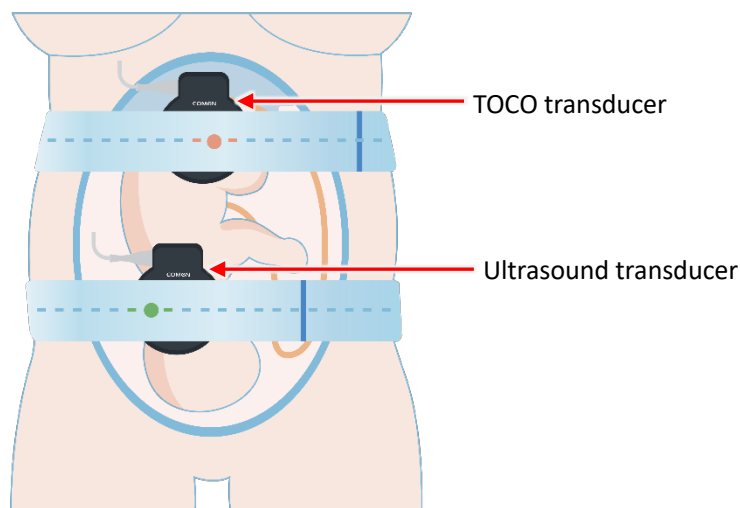

Monitoring Fetal Movement

5.10

Information on fetal movement is obtained from Automatic Fetal Movement (AFM) and Manual Fetal Movement (MFM). See **Section 5.3 Fetal Setup** for more information.

5.10.1 AFM Monitoring

AFM can be detected through the Doppler ultrasound and it differs from FHR signals in that they have greater amplitude and lower frequency. The greater amplitude is due to the relatively large movement range (e.g. fetal arms or legs) and the lower frequency results from the relatively low velocity of fetal movement, compared with the velocity of the fetal heart. Fetal movements can be detected and displayed as AFM on the monitor.

Only fetal heart channel 1 can perform AFM. But during monitoring twins, the movement detected by channel one may also be caused by the movement of the other fetus.

The AFM is obtained by the US transducer. Therefore, AFM can be detected when FHR is being monitored, but only the transducer connected to the channel 1 can monitor fetal movement.

5.10.2 MFM Monitoring

When the patient feels a fetal movement, press the event marker and the results will be displayed on the main screen.

Connect the event marker to the monitor and instruct the patient to operate the event marker: press the button at the top when a fetal movement is felt. Continuous fetal movement within 5s should be considered as one movement and only press the button once.



NOTE

- Before monitoring manual fetal movement, make sure the [FM Source] is set to be [Manual].

Start Monitoring

Press the shortcut key of start monitoring, the monitor will automatically zero the pressure and clear the FM value. See *Section 5.4 Monitoring Setup* for more information.

5.11 5.11.1 Inputting Patient Information

5.11.1.1 Auto ID

If the **[Patient Information]** in the monitoring setup is turned on, after the start monitoring button is pressed, an auto ID will be provided for the patient. The ID consists of the date and time when the monitoring starts.

5.11.1.2 Scanning Patient ID

The patient ID can be entered with a scanner.

- 1) Connect the scanner to the USB connector on the monitor.
- 2) Click the patient information area at the top left corner of the main screen, and **[Patient Information]** will be displayed.
- 3) Scan the barcode/QR code with the scanner, and the patient ID or the registration number will be automatically entered.



NOTE

- Check if the type (Patient ID or Registration No.) of the patient information obtained by the scanner is consistent with settings in **[Scanner Setup]**.
- It is recommended not to use the onscreen keyboard of the monitoring when using a scanner.

5.11.1.3 Editing Patient Information

After pressing the Start button,

- 1) The **[Patient Information]** page will be displayed.
- 2) Select the items below and input related information.
 - ID: 30-character limit
 - Last name/middle name/first name: 20-character limit each
 - Registration No.: 30-character limit
 - Bed No.: 15-character limit
 - Room No.: 15-character limit
 - Height (cm): from 20.0 to 300.0 cm (7.9 to 118.1 inch)
 - Weight (kg): from 0.1 to 499.0 kg (0.2 to 1100.1 lb.)

- Race: Unspecified, Caucasian, Asian, African or Other
- Age: from 0 to 200 years old
- Blood Type: Unspecified, O, A, B, AB and Other
- DOB (Date of Birth): from 1900-01-01 to the current date
- Admission Date: from 1900-01-01 to the current date
- Gestational Age (Week): from 0 to 99
- Gestational Age (Day): from 0 to 6
- Fetus number: from 0 to 50
- Parity: from 0 to 50
- Gravity: from 0 to 50
- Custom 1: 15-character limit
- Custom 2: 15-character limit

3) After inputting the information, select **[OK]** and the page will disappear. At this moment, a new ID will be generated.

Monitoring will not stop while inputting the patient information.



NOTE

- **Only the most recent ID is shown for the same patient.**
- **If printing starts automatically with monitoring, the auto ID will be printed on the recorder paper first, and the new ID can be printed after 10min/20min/30min/60min (based on the settings in [Title Print Interval]).**
- **The change of patient information during monitoring does not affect monitoring or waveform printing.**
- **The information shown in the [Patient Information] can be set up in [Patient Info Manage] in [User Maintenance].**
- **The archived patient information cannot be changed. Therefore, make sure the patient information is entered correctly before monitoring.**
- **It is recommended to enter the key patient information (such as the patient's name or ID) before monitoring to avoid data loss.**

Chapter 6 Alarms

When a patient under monitoring has abnormal vital signs, or when a failure occurs in the monitor, the system sounds audible and visual alarms to remind the user.

When there are multiple alarms and prompt messages, messages scroll in a cycle.

Safety Information

6.1 WARNING

- If restarted within 30s after power-off or power loss, the latest configurations will be loaded automatically.
- The alarm system will become useless if setting alarm limits to extreme limits.
- A hazard can exist if different alarm presets are used for the same or similar equipment in any single area, e.g. an intensive care unit or cardiac operating theatre.
- Both the bedside monitor and the CMS are provided with sound alarm function.
- When this monitor is connected to the CMS, you can use the same high and low alarm limits for the monitor and CMS. If you enable alarm delay on this monitor, the monitor will not display an alarm when the CMS indicates an alarm.
- When multiple alarms of different levels are generated simultaneously, the monitor will activate the alarm sound and light for the highest-priority alarm condition.
- The device can be reset to factory settings and the alarm limits will also be changed accordingly. Refer to *Appendix IV Default Configuration* for details.
- When the monitor is turned on, the alarm system will be automatically activated and a self-test of alarm sound and alarm indicator will be performed. If self-test failure or alarm system failure occurs, do not use the device and contact the company.

6.2 NOTE

- The pressure level of alarm sound generated by this monitor is 45-85db.

Alarm Types

Alarms generated by the monitor are classified into physiological and technical alarms.

- Physiological alarm

A physiological alarm is generated when a certain physiological parameter of the patient is beyond the

high/low alarm limit or the patient has a physiological disorder. Physiological alarm messages are displayed in the physiological alarm area in the upper part of the screen.

- Technical alarm

A technical alarm is triggered when the monitor does not operate normally or the monitoring result is unreasonable due to improper operation or system failure. A technical alarm message is displayed in the technical alarm area in the upper part of the screen.

- Prompt message

In addition to physiological and technical alarms, the monitor also shows messages about system status. Generally, these messages shown in the system message area are not related to vital signs of the patient.

Alarm Signals

6.3 6.3.1 Alarm Indicator

The alarm indicator lights will indicate different priorities of alarms generated in different colors and flashing frequencies.

- High-priority alarm: Red, flashing fast
- Medium-priority alarm: Yellow, flashing slowly
- Low-priority alarm: Yellow, constantly on

6.3.2 Audible Alarm

The monitor indicates alarm levels with alarm sounds with different intervals.

- High-level: beep-beep-beep--beep-beep----beep-beep-beep--beep-beep
- Medium-level: beep-beep-beep
- Low-level: beep

6.3.3 Alarm Messages



NOTE

- **In the event of power failure, the log of power failure will not be saved.**
- **The log will not change if the monitor is powered off or disconnected from the power supply.**

Alarm messages are shown in the physiological alarm area or technical alarm area on the screen.

Different background colors are used to indicate the alarm levels:

- High-level: Red
- Medium-level: Yellow

- Low-level: Cyan

Different marks are added in front of alarm messages to indicate the alarm levels:

- High-level: ***
- Medium-level: **
- Low-level: *

6.3.4 Alarm Parameter Flashing

- ◆ High-level alarm: Red background, flashing
- ◆ Medium-level alarm: Yellow background, flashing
- ◆ Low-level alarm: Cyan background, constantly on

6.3.5 Alarm Status Icons



Alarm paused



Alarm off: a certain parameter or the alarm system



Audio paused



Audio off



Alarm reset

6.4

Parameter Alarm ON/OFF

The alarm switch of the fetal parameters and the maternal parameters can be turned on/off in different ways.

- 1) Select a parameter area to enter the corresponding setup page.

6.5

- 2) Turn on or off the [Alarm Switch] as required.

Alarm Levels

- High-level alarm: The patient is in critical condition or the device has serious failure, and immediate response is necessary.
- Medium-level alarm: The patient's physical signs are abnormal, the device has failure or is misoperated, and timely response is necessary.
- Low-level alarm: The patient's physical signs are abnormal, the device has failure or is misoperated, and the user is required to understand the current situation.

- Prompt messages: Information on the patient and system status should be provided.

6.5.1 Set Alarm Level

The alarm level of the fetal parameters and the maternal parameters can be set up in different ways.

- 1) Select a parameter area to enter the corresponding setup page.
- 2) Set the [Alarm Level] as required.

Set Alarm Limit

6.6 The alarm limits of the fetal parameters and the maternal parameters can be set up in different ways.

- 1) Select a parameter area to enter the corresponding setup page.
- 2) Set the [Alarm Limit] as required.

Alarm Setup

6.7

Enter [User Maintenance] → [Alarm] to set the alarm volume, alarm pause/reset and other items.

6.7.1 Volume

Enter [User Maintenance] → [Alarm] → [Volume] and you can set up [Minimum Alarm Volume], [Auto Increase Volume] and [Increase Volume Delay]:

- [Minimum Alarm Volume]: press **+** or **−** to increase or decrease the minimum alarm volume.
- [Auto Increase Volume]/[Increase Volume Delay]: If the alarm is not acknowledged after the set time in [Increase Volume Delay], the alarm volume will be automatically increased to the level set in [Auto Increase Volume].
 - [Auto Increase Volume]: can be set to [Level 2], [Level 1] or [OFF]. If [OFF] is selected, the alarm volume will not change.
 - [Increase Volume Delay]: can be set to 30s, 20s or 10s.
- [Restore Defaults]: Press the button to restore the settings in this page to the default.



WARNING

- When the [Minimum Alarm Volume] is set to 0 and the alarm volume is turned off, no alarm will be sounded even if a new alarm is generated.
- Do not rely only on the audible alarm. Otherwise, patient safety may be at risk if the alarm volume is low. Pay close attention to the patient's actual clinical conditions.

6.7.2 Pause/Reset

Enter [User Maintenance] → [Alarm] → [Pause/Reset] and you can set up the following items:

- Pause: The user can set [Pause] to [Alarm Pause] or [Alarm Audio Pause]. See *Section 6.7.2.1 Alarm Pause* or *Section 6.7.2.2 Alarm Audio Pause*.
- Pause Time: Set the pause time to [1 min], [2min], [3min] and [Permanent]. If the pause time is set to [Permanent], the alarm system or the alarm audio will be turned off. See *Section 6.7.2.3 Alarm Off* and *Section 6.7.2.4 Alarm Audio Off* for details.
- [Pause 5 min]/ [Pause 10 min]/ [Pause 15 min]: Turn on the switch and the alarm can be paused for the corresponding period of time. When the alarm/alarm audio is paused, click the alarm information area on the main screen and the [Pause X min] button is shown at the bottom right corner of the displayed [Alarm review] page. Press the button and the alarm/alarm audio can be paused for the time set.
- [Alarm Light]: Set the alarm light to [On When Reset] or [Off When Reset].
 - [On When Reset]: when the alarm is reset, the alarm sound of the current alarms will be turned off, but the alarm indicator still flashes.
 - [Off When Reset]: when the alarm is reset, the alarm sound and alarm indicator of the current alarms will both be turned off.
- [Reminder Interval]/[Alarm Reset Reminder]/[Alarm Off Reminder]: See *Section 6.7.2.5 Reminder Interval* for details.
- [Restore Defaults]: Press the button to restore the settings in this page to the default.



WARNING

- If the alarm paused shortcut key is pressed and the [Pause Time] is set to [Permanent], no alarm will be sounded even when a new alarm is generated.

6.7.2.1 Alarm Pause

If the [Pause] is set to [Alarm Pause], press the alarm paused shortcut key, and:

- Pause all physiological alarms.
- Pause the audio of all technical alarms but the alarm lights and alarm messages remain.
- Display the remaining time of alarm paused in the physiological alarm message area.
- Display the alarm paused icon in the alarm message area.

The monitor will recover from the alarm paused status after the alarm paused time expires. You can also press the alarm paused shortcut key to cancel the alarm paused status.

6.7.2.2 Alarm Audio Pause

If the [Pause] is set to [Alarm Audio Pause], press the audio paused shortcut key, and:

- The alarm audio of physiological alarms and technical alarms will be turned off in the specified time.
- Display the remaining time of alarm paused in the physiological alarm message area.
- Display the audio paused icon in the alarm message area.

The monitor will exit the alarm audio paused status automatically when the specified paused time expires. You can also click alarm audio paused shortcut key to cancel the alarm audio paused status.

6.7.2.3 Alarm Off

If the [Pause] is set to [Alarm Pause] and [Pause Time] is set to [Permanent], the alarm paused shortcut key will change to alarm off key. Press the key and:

- The light and audio of physiological alarms will be cancelled.
- The technical alarm audio will be turned off, but the alarm lights and alarm messages remain.
- [Alarm Off] will appear in a red background at the physiological message area.
- The alarm off icon will be shown in the message area.

Click the alarm off shortcut key again to exit the alarm off status.



WARNING

- Risk may exist if the alarm is paused or turned off. The user should pay close attention to the actual clinical conditions of patients.

6.7.2.4 Alarm Audio Off

If the [Pause] is set to [Alarm Audio Pause] and [Pause Time] is set to [Permanent], the audio paused shortcut key will change to audio off key. Press the key and:

- The alarm audio of physiological alarms and technical alarms will be cancelled.
- [Alarm Audio Off] will appear in a red background at the physiological message area.

Click the audio off shortcut key again to exit the audio off status.



WARNING

- Risk may exist if the alarm audio is paused or turned off. The user should pay close attention to the actual clinical conditions of patients.

6.7.2.5 Reminder Interval

When [Alarm Reset Reminder] and [Alarm Off Reminder] are turned on, and the alarm function is turned off,

the alarm audio is turned off, or the alarm is reset, the monitor will provide a periodic reminder tone to remind the user of the situation that there is still activated alarm in the current system.

- **[Alarm Reset Reminder]/[Alarm Off Reminder]**: turn on or off the switch
 - ON: the monitor will generate an alarm reminder at set intervals.
 - OFF: the monitor will not generate the alarm reminder, and the confirmed physiological alarm and the non-clearable technical alarm will be muted permanently.
- **[Reminder Interval]**: Set the interval to **[10min]**, **[5min]**, **[3min]**, **[2min]** and **[1min]**.

6.7.3 Other

Enter **[User Maintenance]** → **[Alarm]** → **[Other]** to set up the items below:

- **[OB Alarm System Control]**: turn on or off the switch.
 - On: the obstetric central monitoring system can control the alarm system of the monitor.
 - Off: the obstetric central monitoring system cannot control the alarm system of the monitor.
- **[Restore Defaults]**: Press the button to restore the settings in this page to the default.

Alarm Reset

6.8

Click the Alarm Reset shortcut key to acknowledge the current alarms and reset the alarm system. Then the alarm reset icon will appear in the system status information area.



NOTE

- **If a new alarm is generated when the monitor is in alarm reset state, the alarm reset icon will disappear and the sound/light of the alarm will function normally.**

6.8.1 Physiological Alarm Reset

When the physiological alarm is reset:

- The sound of existing physiological alarm will be mute.
- The √ sign appears in front of the alarm message, indicating that the alarm is acknowledged.
- The background color of the measured value will flash.

6.8.2 Technical Alarm Reset

When the technical alarm is reset:

- Fully clearable technical alarms will be cleared. The monitor will give no warning of the cleared technical alarms.
- Clearable sound and light alarms will be displayed as a prompt message.
- Not fully clearable technical alarms will be mute. The √ sign will appear before the alarm message,

indicating that the alarm is acknowledged.

Alarm System Test

When the monitor is turned on, the alarm system will perform the self-test on alarm light and alarm audio.

During the self-test:

- 6.9**
- 1) The alarm indicator will light up in red and yellow in turn, and then the indicator will be turned off.
 - 2) During the self-test of alarm indicator, a “beep” will be sounded.

If a further test of alarm system is required, a relative simulator is required and adjust the alarm limits to verify whether the correct alarm response can be triggered.

Overview

This chapter includes fetal monitoring review and alarm review.

- 7.1 ● Fetal monitoring review: reviews waveforms of FHR1, FHR2, TOCO and AFM. Up to 24 hours of waveform review of a single patient can be stored.
- Alarm review: reviews current and previous technical and physiological alarms.

Search Patient Information

7.2



Press the patient information area to enter [Patient Information] → press  to enter [Search Patient Info].

The user can view the previous patient data.

Each file is arranged in chronological order and consists of an ID, name and start time of monitoring. Select the

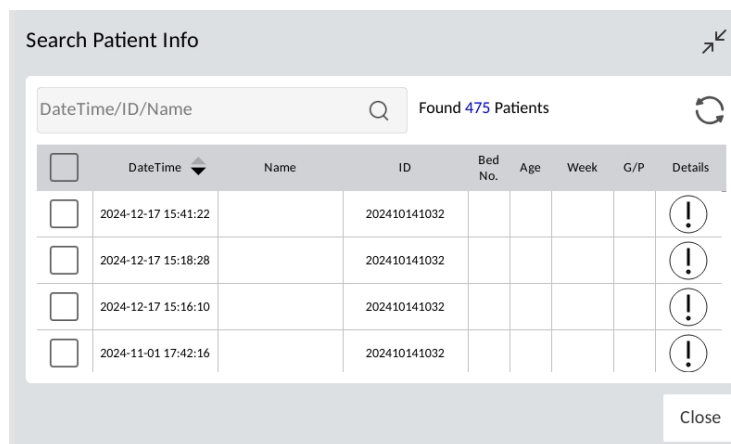
icon  of a record to review the fetal monitoring information and alarm information.



- Switch the patient information window: Press  at the upper right corner of the [Search Patient Info] page to switch to the information page of the current patient.
- Search patient information: select [Date Time/ID/Name] text box → input corresponding information → press  to search the required patient.
- Refresh: press  to refresh the patient list.
- List order: Press [Date Time] at the top of the chart to list the patient information in chronological or reverse-chronological order.

- Select patient information: select the box of each patient file to select one single file or the box at the top of the list to select all the files.
- Delete patient information: see **Section 4.3.13 Patient File Management** for details.
- View details: press  and the user can review **[Fetal Review]** and **[History Alarm Review]**.





NOTE

- Fuzzy search is available in the **[Date Time/ID/Name]** text box.
- The patient data cannot be deleted during printing.
- The deleted data cannot be recovered. Please operate with caution.
- When the data storage (up to 500 files or 5000 hours of data) is full, the monitor automatically deletes the earliest patient data. Therefore, export and archive the files in time.
- After more than 500 files or more than 5000 hours of data are stored, it may take too long for the monitor to load the data. Export the patient files in time and delete them.
- At most 500 technical alarms and 500 physiological alarms can be stored. The earliest alarms will be deleted if the alarm event storage is full.

7.3 Fetal Review

7.3.1 Enter/Exit the Fetal Review Interface

The user can review the fetal monitoring information of the current patient or previous patients.

- To review the fetal monitoring of the current patient: press  shortcut key on the main screen.
- To review the fetal monitoring of previous patients: in the **[Search Patient Info]** page, press  and enter **[Review]** → **[Fetal Review]**.

Exit the review page as follows:

- Press the review shortcut key  again to exit the review page and you can perform other operations.

7.3.2 Fetal Monitoring Review Interface

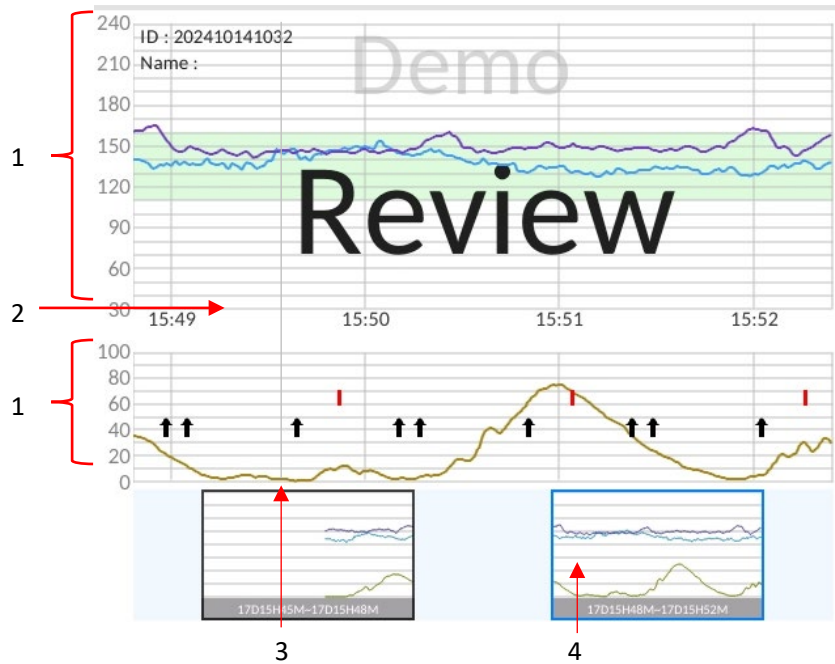

In the review interface, the user can view the monitoring waveforms of the current (or previous) patient.



1. Waveform area: displays the waveforms of FHR1/2, TOCO and AFM. The waveforms are shown in the same color as the corresponding parameters.
2. The time scale of the current window being reviewed
3. Time Cursor
4. Thumbnails: The waveform area displays the waveforms of the selected thumbnail. At most 6 thumbnails can be shown on the screen, and if more patient information is required, swipe the thumbnails to the left or to the right.



NOTE

- The monitor will display the waveform of the latest thumbnail by default after entering the review interface.
- The  key and  key are invalid during review. Press the review key  again to exit review interface.

7.3.3 Print Fetal Monitoring Waveform

- 1) After entering the review page, select the fetal monitoring waveform of the desired period.
- 2) Click the record or print shortcut key and the related printer will print the waveform of the corresponding period of time.
 - If no time cursor is shown at the waveform area and the shortcut key is pressed, the waveform of the whole time scale in the selected thumbnail will be printed.
 - If the time cursor is shown and the shortcut key is pressed, then the waveform between the selected time of the time cursor and the end time of the thumbnail will be printed.

**NOTE**

- See *Chapter 8 Print* for more information of the printing setup.

Alarm Review

7.4.1 Enter/Exit Alarm Review Interface

7.4 The user can review the alarms of the current patient or previous patients.

- To review the alarms of the current patient: press the alarm information area on the main screen to enter [Alarm Review] page.
- To review the alarms of previous patients: in the [Search Patient Info] page, press  and enter [Review] → [History Alarm Review].

Exit the review page as follows:



- Press the [Close] button at the lower right corner.

7.4.2 Alarm Review Interface

At most 500 physiological alarms and 500 technical alarms can be reviewed in [Alarm Review] or [History Alarm Review].

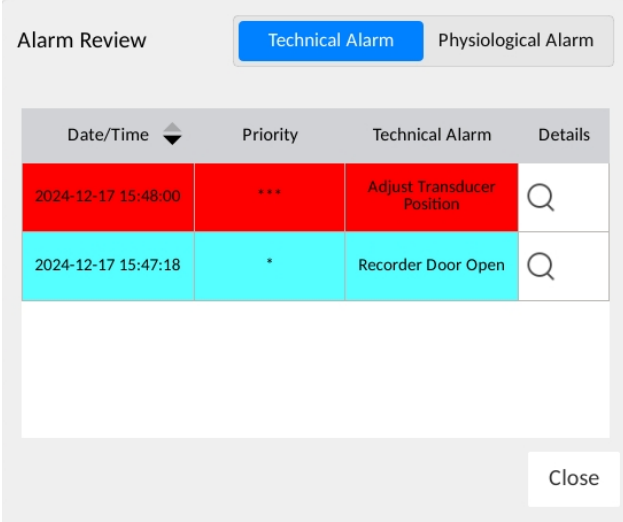
Press [Technical Alarm] and [Physiological Alarm] to view the corresponding information.



Date/Time	Priority	Technical Alarm	Details
2024-12-17 15:48:00	***	Adjust Transducer Position	
2024-12-17 15:47:18	*	Recorder Door Open	

- Press [Date/Time] to list the alarms in chronological or reverse-chronological order.
- Press [Priority] to list the alarms based on alarm level.
- Different priorities of alarms are shown in different background colors. See *Section 6.3.3 Alarm Messages* for details.



NOTE

- To display [Pause 5 min]/ [Pause 10 min]/ [Pause 15 min] in the [Alarm Review] page:
 - [User Maintenance] → [Alarm] → [Pause/Reset] → enable [Pause 5 min]/ [Pause 10 min]/ [Pause 15 min]
 - The device is in alarm paused state.
- The activation of [Pause 5 min]/ [Pause 10 min]/ [Pause 15 min] extends the current pause time but will not affect the set value in [Pause Time].

Overview

8.1 The monitor can record the information of fetal and mother monitoring through a built-in thermal recorder, and also prints corresponding reports through an external printer.



NOTE

- Lower operating temperature may cause blurred marks during recording. Enter [User Maintenance] → [Print Setup] → set up the line width of FHR1/FHR2 /AFM/TOCO.

External Printer

8.2 The monitor can print patient reports through the connection with a printer via a USB adapter cable. The following printers can be connected:

- HP LaserJet Pro3004dw
- HP LaserJet Pro4004d
- HP LaserJet Pro4003d

The printout specification should be:

- Paper size: A4
- Resolution: 300dpi
- Printer language: Printer Control Language (PCL)
- Print on one sided or both sided



NOTE

- 8.3
- Refer to the instruction for use of the external printer for more details on the printer connected.

Recorder Paper

Four types of recorder paper can be provided as required:

Specification	Text on the recorder paper
Z-fold recorder paper/no black mark/ GTB306-KM /152*90/150	30-240-G-GTB306-KM
Z-fold recorder paper/black mark/ GTB305-KM /150*100/150	30-240-P-GTB305-KM

Z-fold recorder paper/ black mark/ GTB303-KM /150*100/150	50-210-P-GTB303-KM
Z-fold recorder paper/ no black mark/GTB309-KM /152*90/150	50-210-G-GTB309-KM

**NOTE**

- **The type of recorder paper applied should be in consistent with the paper type set in the monitor. Contact the company if there is any doubt.**
- **Different installation is required for recorder paper with different width. See *Section 3.4 Installation of Recorder Paper* for details.**

Print Setup

8.4 In [Print Setup], there are [Record Setup] and [Report Setup]:

- **[Record Setup]:** Sets up the fetal monitoring report which is to be printed through the built-in recorder.
 - Fetal monitoring: FHR waveform, fetal analysis, event marks and so on.
- **[Report Setup]:** Sets up the fetal monitoring report which is to be printed through an external printer.
 - The report includes FHR waveform, CTG score, event marks and so on.

8.4.1 Recording Setup of Fetal Monitoring

Press the  shortcut key → [Print Setup] → [Record Setup] define the recording settings in Fetal Screen and Review interface.

8.4.1.1 Paper Speed

- 1) Press the  shortcut key → [Print Setup] → [Record Setup] → [Paper Speed]
- 2) Select [1 cm/min], [2 cm/min] or [3 cm/min] (default).

8.4.1.2 Duration

Only a fixed time length of waveform can be printed. Set up the time length as follows:

- 1) Press the  shortcut key → [Print Setup] → [Record Setup] → [Duration]
- 2) Set the duration to [Infinite] or 10 min – 90 min (the step is 5min).
 - If X min is selected, the recorder stops when the time is up.
 - If [Infinite] is selected, there is no time limit.

**NOTE**

- Press the print button again or the current monitoring ends, and the printing will stop.

8.4.1.3 Print Self-test

If the [Print Selftest] is turned on, a self-test curve will be automatically printed when the monitor is turned on to check whether the recorder paper is correctly installed.

- 1) Press the  shortcut key → [Print Setup] → [Record Setup] → [Print Selftest]
- 2) Set [Print Selftest] to be on or off (default).

**NOTE**

- After [Print Selftest] is turned on, reboot the monitor and the self-test curve can be printed.
- Before start printing, make sure that the recorder paper is installed correctly.

8.4.1.4 End Tone

- 1) Press the  shortcut key → [Print Setup] → [Record Setup] → [End Tone]
- 2) Set [End Tone] to be on or off (default).

If it is turned on, a sound will be heard when the printing ends.

8.4.1.5 End Tone Volume

- 1) Press the  shortcut key → [Print Setup] → [Record Setup] → [End Volume Level]
- 2) Select [Low], [Med] or [High].

8.4.1.6 FHR2 Offset

See *Section 5.8.3.3 FHR2 Offset* for details.

8.4.1.7 Title Print Interval

The heading will be printed at an interval set in [Title Print Interval].

- 1) Press the  shortcut key → [Print Setup] → [Record Setup] → [Title Print Interval].
- 2) Select [5 min], [10 min] (default), [20 min], [30 min] or [60 min].

8.4.1.8 Separation Print

If the function is enabled, the twin FHR traces will be printed separately.

- 1) Press the  shortcut key → [Print Setup] → [Record Setup] → [Separation Print]
- 2) Set it to be on or off (default)
 - ON: The trace of FHR1/2 can be printed separately. During real-time monitoring, the recorder will print the FHR1 trace at the set speed and then quickly (25mm/s) print the FHR2 trace.
 - OFF: The FHR1/2 traces will be printed together.



NOTE

- Separation print is applicable to real-time monitoring and fetal monitoring review.

8.4.1.9 Data Caching

The printing pauses when the monitor runs out of recorder paper or when the recorder door is open. If the [Data Caching] is enabled as follows and the recorder door is closed, the monitor will print the cached data within 60 minutes.

- 1) Press the  shortcut key → [Print Setup] → [Record Setup] → [Data Caching]
- 2) Set it to be on or off (default).

If it is set to be ON:

 - The data will be saved for at most 60 minutes after the printing pauses. If the recorder paper is loaded or the recorder door is closed, the monitor will print the cached data at a speed of 25mm/s. When the monitor finishes printing the cached data, it prints the current monitoring data.
 - If the recorder paper is not loaded or the recorder door is not closed within 60 min, the monitor will stop printing.

If it is set to be OFF, printing stops when the monitor runs out of recorder paper or when the recorder door is open.





NOTE

- If data caching is disabled, make sure the recorder paper is sufficient and the recorder door is closed correctly.

8.4.1.10 Print CTG Score

The device can print the CTG report of the real-time monitoring or the previous fetal monitoring.

- 1) Press the  shortcut key → [Fetal Setup] → [CTG Score]

- If [CTG Score] is set to be off, no CTG report can be previewed and printed.
- 2) Press the  shortcut key → [Print Setup] → [Record Setup] → [Print CTG Score]
 - 3) Turn on or off [Print CTG Score]: it is turned off by default.
 - ON: the device prints reports based on the set CTG score type.
 - OFF: no CTG report will be printed.

**NOTE**

- If the printing does not last more than 10 minutes or invalid data (10% of the monitoring FHR is beyond the range of 30 and 240 bpm) is printed, no CTG analysis can be printed.
- At most 60 minutes of CTG score can be printed. If the printing lasts more than 60 minutes, the monitoring data beyond 60 minutes will not be analyzed.
- Make sure that [CTG Score] in [Fetal Setup] is NOT set to [OFF], or CTG analysis score cannot be printed.
- During the printing of real-time CTG, if the printing lasts between 10 and 60 minutes, the printed CTG score is analyzed based on the actual printing duration.
- During the printing of previous CTG:
 - Do not stop the printing manually during the printing of previous monitoring data, or CTG analysis will fail.
 - If the [Duration] in [Print Setup] > the duration the previous fetal monitoring to be printed ≥ 10 min, the monitor will analyze the CTG based on the actual printing duration.
 - If the duration the previous fetal monitoring to be printed > the [Duration] in [Print Setup] ≥ 10 min, the monitor will analyze the CTG based on the set duration in [Print Setup].

8.4.1.11 Fetal Analysis

Auxiliary analysis of the fetal monitoring is provided as the baseline or the score to assess fetal vital signs.

- Baseline: The average FHR over 10 minutes, excluding accelerations, decelerations and periods of marked FHR variability.
- Score: Identification and analysis of fetal accelerations and decelerations.

Follow the steps below to set up [Fetal Analysis]:

- 1) Press the  shortcut key → [Print Setup] → [Record Setup] → [Fetal Analysis]
- 2) Select [OFF](default), [Baseline] or [Score]:
 - [Baseline]: only the FHR baseline is displayed in the report.
 - [Score]: both the FHR baseline and auxiliary score are displayed in the report.

Note on the score in the report:

For example, if the report shows , an acceleration is detected.

**NOTE**

- The fetal analysis can only be printed in Review page.
- The FHR baseline and FHR score can be acquired 10 min after the monitoring starts, and a maximum of 60 min baseline and score can be obtained.

8.4.1.12 Fetal Analysis Channel

Auxiliary analysis of the fetal monitoring will be provided to FHR1/2 based on the setting in [Fetal Analysis Channel].

- 1) Press the  shortcut key → [Print Setup] → [Record Setup] → [Fetal Analysis Channel]
- 2) Set [Fetal Analysis Channel].

**NOTE**

- Make sure that in the selected fetal analysis channel, the valid monitoring data should be of more than 10 minutes.

8.4.2 Report Setup

In [Print Setup] → [Report Setup], you can set up the report type, resolution and printing duration.

8.4.2.1 Report Type

- 1) Press the  shortcut key → [Print Setup] → [Report Setup] → [Report Type]
- 2) [Realtime Fetal Report] is selected by default.

8.4.2.2 Resolution

- 1) Press the  shortcut key → [Print Setup] → [Report Setup] → [Resolution]
- 2) Select [1 cm/min], [2 cm/min] or [3 cm/min] (default)

8.4.2.3 Print Duration

See **Section 8.4.1.2 Print Duration** for more information. At most 60 min of report can be printed.

8.4.2.4 FHR1/FHR2 Switch

- 1) Press the  shortcut key → [Print Setup] → [Report Setup] → [Resolution]
- 2) Enable or Disable the waveform switch of FHR1/FHR2.

8.4.2.5 Print CTG Score

See **Section 8.4.1.10 Print CTG Score** for more information.









8.4.2.6 Start Printing

Follow one of the following ways to start printing:

- Press the Print shortcut key .
- Press the  shortcut key → [Print Setup] → [Report Setup] → Select the [Start Print] button to initiate printing.

8.5 Event Marks

The event marks on the screen may be shown as a different mark in the report and the description of the event marks are as follows:

Event	Mark on screen	Mark in report	Remarks
DRUGS	A	A	Press the  when [Smart Notes] in the [Fetal Setup] is turned off.
POSITION	B	B	
MEMBRANES	C	C	
PROCEDURES	D	D	
OTHER	E	E	
ANTENATAL	F	F	
REASON	G	G	
Smart Note		N	Press the  when [Smart Notes] in the [Fetal Setup] is turned on.
Fetal Stimulator	 (Red)	H	These marks are shown on the 0-100 waveform area.
Manual fetal movement (Black Mark)			
Auto fetal movement (Black Mark)	 (Black)	 (Black)	

Zero TOCO		K	
-----------	---	---	--

Start Recording/Printing

8.6.1 Start Recording Manually

- 8.6 Press the shortcut key of recording to start real-time recording.

8.6.2 Start Printing Manually

See **Section 8.4.2.6 Start Printing** for more information

8.6.3 Start Recording Automatically

- 1) Press the  shortcut key → [Monitoring] → [Auto Print]
- 2) Set it to be on or off (default).



NOTE

- If the [Auto Print] is turned on, only fetal monitoring information can be automatically recorded through the built-in recorder.

8.7

Stop Recording/Printing

8.7.1 Stop Recording Manually

Press the shortcut key of recording to stop real-time recording.

8.7.2 Stop Recording/Printing Automatically

The Recorder will stop recording automatically in the following cases:

- The recording/printing task has been completed.
 - The recorder has run out of paper.
 - The recorder/printer fails to work properly due to a technical fault.
 - The battery is 20% or lower when the device is not connected to an AC power supply.
- 8.8

Paper Advancing

Press and hold the shortcut key  to advance the recorder paper and you can tear off the paper along the

perforation.

**NOTE**

- The Paper Advance key is not valid during printing.
- If the shortcut key  does not display on the main screen, see *Section 4.2.7 Custom Shortcuts* for details.

Clear Paper Jams

8.9 If the recorder makes any abnormal sound during running or the recorder paper outputs abnormally, check if there is a paper jam. If the paper is jammed, clear the jam according to the following steps:

- 1) Open the recorder door.
- 2) Take out the paper, and cut off the folded part.
- 3) Reload the paper, and close the recorder door.

Cleaning of the Recorder

8.10

After using the recorder for long periods, scraps of paper and impurities could accumulate on the print head, which affects the quality of recording and the service life of print head and roll shaft. Follow the steps below the clean the recorder every 2 months or as required:

- 1) Before cleaning the recorder, prevent the equipment from being damaged by static electricity.
- 2) Open the recorder door; take out the paper.
- 3) Then use a cotton ball dipped into a small amount of alcohol and gently wipe the surface of the thermal part of print head.
- 4) When the alcohol residue on the print head becomes completely dry, reload the paper and close the recorder door.

**NOTE**

- Do not use any materials (such as abrasive paper) that can damage the thermal print head.
- Do not squeeze the thermal print head with force.

Chapter 9 CTG Score

Various scores are provided in the monitor. Set the CTG score as follows:

- 1) Press the  shortcut key → [Fetal Setup] → [CTG Score].
- 2) Select the scoring criteria as required: [OFF], [KREBS Score], [Fischer Score], [Modified Fischer Score], [NST Score], [NST Report], [NST Three-Tier Classification] and [Oxford Report].

1. KREBS Score

Item	0 point	1 point	2 points	Results (FHR 1/2)	Score (FHR 1/2)
FHR Base/bpm	<100/>180	100~109/161~180	110~160		
Amplitude Variability/bpm	0~4	5~9/>25	10~25		
Periodic Variability/cpm	0~2	3~6	>6		
Acceleration	0	1~4	>4		
Deceleration	>2	1~2	0		
FM	0	1~4	>4		

2. Fisher Score:

Item	0 point	1 point	2 points	Results (FHR 1/2)	Score (FHR 1/2)
FHR Base/bpm	<100/>180	100~109/161~180	110~160		
Amplitude Variability/bpm	0~4	5~9/>25	10~25		
Periodic Variability/cpm	0~1	2~5	>5		
Acceleration	None	Periodic Acc. (Periodic Acceleration)	Non-periodic Acc. (Non periodic acceleration)		
Deceleration	LD (Late Deceleration), Severe VD (Severe Variable Deceleration)	ED (Early Deceleration), Mild VD(Mild Variable Deceleration)	None, Occasional Dec.(Occasional Deceleration)		

3. Modified Fischer Score:

Item	0 point	1 point	2 points	Results (FHR 1/2)	Score (FHR 1/2)
FHR Base/bpm	<100/>180	100~109/161~180	110~160		
Amplitude Variability/bpm	0~4	5~9/>30	10~30		
Periodic Variability/cpm	0~1	2~6	>6		
Acceleration	0	1~4	>4		
Deceleration	LD (Late Deceleration)	VD (Variable Deceleration)	None, Occasional Dec.(Occasional Deceleration)		

4. NST Score:

Item	0 point	1 point	2 points	Results (FHR 1/2)	Score (FHR 1/2)
FHR Base/bpm	<100/>180	100~109/161~180	110~160		
Amplitude Variability/bpm	0~4	5~9/>25	10~25		
FM Rise Time/s	0~9	10~14	>14		
FM Rise Range/bpm	0~9	10~14	>14		
FM	0	1~2	>2		

5. NST Report

Item	FHR 1	FHR 2
Signal Loss Rate		
TOCO		
FHR Base/bpm		
Acceleration		
Deceleration		
Short-term Variability		
Long-term Variability		
FM		

6. NST Three-Tier Classification

Item	Normal	Suspicious	Abnormal	FHR1	FHR2
FHR Base/bpm	110~160	100~109/>160 (<30min)	<100/>160 (≥30min)		
Amplitude Variability/bpm	6~25; ≤5 (<40min)	≤5 (≥40min)	≥25 (>10min)		
Acceleration	≥2 (<40min)	<2 (40-80min)	<2 (>80min)		
Deceleration	None, Occasional Dec.	VD 30-60s	LD (Late Deceleration), Severe VD (Severe Variable Deceleration)		
Sinusoidal Pattern	None	None	Present		

7. Oxford Report

Item	FHR 1	FHR 2
Signal Loss Rate		
TOCO		
FM/Hour		
FHR Base/bpm		
Acceleration (>10bpm&15s)		
Acceleration (>15bpm&15s)		
Deceleration (>20 loss)		
High Variability		
Low Variability		
Short-term Variability		

**NOTE**







- CTG analysis is provided as a reference for the healthcare professionals to interpret the waveforms. Conclusions shall be drawn on the basis of the patient's actual conditions.
- The CTG analysis result can be obtained after the monitoring has been started for at least 10 minutes.
- At most 60 minutes of CTG score can be analyzed. If the fetal monitoring is of more than 60 minutes, the monitoring data beyond 60 minutes will not be analyzed.

Chapter 10 Battery

Overview

The monitor is equipped with a built-in rechargeable battery. The battery will be charged automatically once the monitor is connected to the AC power supply, regardless of whether the monitor is turned on or turned off. In the event of a sudden power failure, this monitor will automatically operate on the battery without any interruption to the monitor functions, and if the AC power supply is disconnected, the battery indicator will flash.

The battery icon displayed on the screen indicates the current battery status:

Symbol	Explanation	Remaining
	The battery is full.	51% - 100%
	The battery is not full.	31% - 50%
	The battery is low.	≤30%
	The battery is critically low and a high-level alarm will be triggered.	≤15%
	The battery is critically low and a countdown to shutdown will be shown.	≤10%
	The battery is being charged.	/
	no battery or a damaged battery	/



WARNING

- Improper replacement of the lithium battery will result in unacceptable equipment risk.
- Battery electrolyte is hazardous. In the event that battery electrolyte comes into contact with your skin or enters your eyes, wash it with clean water immediately and seek medical help.
- Keep the battery out of the reach of children.
- When the battery is being used operationally, the monitor powers off automatically when the battery is low.
- If restarted after powering off within 30s, the device automatically uses the latest configurations.



NOTE

- If the battery is not to be used for a long period of time, please remove the battery and store it properly.

- If the monitor is provided with a built-in battery, the battery must be charged after each use to ensure sufficient charge.

Viewing Battery Information

- 1) Press the  shortcut key → [Maintain] → enter the maintenance password.
- 10.2) Select [Battery Information].

Conditioning and Checking Battery Performance

10.3.1 Conditioning Battery Performance

If it is the first time that the battery is being used, ensure that the battery has undergone at least two complete conditioning cycles. A complete conditioning period means uninterrupted charging until the battery is fully charged, and then discharging it until the monitor shuts down automatically. The battery's performance will gradually decrease as the time of use increases. It is recommended that you optimize the battery every three months. If it is not optimized during a long time, the displayed battery voltage level may not be accurate.

When conditioning the battery, follow these steps:

- 1) Completely disconnect the monitor from the patient and stop all monitoring and measurement.
- 2) Put the battery for conditioning in the battery compartment of the equipment.
- 3) Please ensure that the battery is charged uninterruptedly till it is fully charged.
- 4) Disconnect the AC power supply, and use the battery to supply power to the monitor until the monitor shuts down automatically.
- 5) Battery conditioning is complete.

10.3.2 Checking Battery Performance

The battery service life varies with the storage and operational environments, frequency of battery discharging and charging times. The battery performance degrades gradually even if the battery is not used. It is recommended to check the battery performance every three months.

Check the battery performance in the same way as steps 1 to 4 in **Section 10.3.1 Conditioning Battery Performance**. The length of discharging time reflects the performance of the battery. When the discharge time is significantly lower than the time stated in the specifications, replace the battery.



NOTE

- In order to prolong the service life of the rechargeable battery, if the battery is to be stored for a long period of time, it is suggested that the battery is charged every three months to prevent excessive discharging.
- The power supply time of the battery depends on the configuration and operation of the equipment.

Battery Recycling

10.4 If the battery is obviously damaged or will not charge, it should be replaced. Dispose of batteries in accordance with applicable laws and regulations or the rules of the hospital.



WARNING

- Do not squeeze, puncture, disassemble or short-circuit the battery; otherwise the battery may cause fire or explosion.

Chapter 11 Cleaning and Disinfection

Only materials and methods listed in this chapter that are approved by the company can be used for cleaning or disinfection of the equipment. For any damage arising from use of unapproved materials or methods, the damage will not be covered by the warranty.

The company does not assume any liability for the effectiveness of listed chemicals or methods when they are used as infection control means. For infection control methods, consult the Infection Prevention Department or an epidemiologist in your hospital. Besides, refer to local policies that apply to your hospital and country.

Overview

11.1

This chapter describes the cleaning and disinfection methods of device and some accessories. For information on the cleaning and disinfection of other non-disposable accessories, refer to the instruction manual of the accessories.

Please keep the device and its accessories dustless. After cleaning, please check the device carefully. If there is any evidence of ageing or damage, please stop using it immediately. If it is necessary to send back the device to Comen for repair, first clean it. Please observe the following precautions.



WARNING

- **Only use detergents and disinfectants recommended in this manual. Using other detergents and disinfectants may result in damage to the equipment or other risks.**
- **Do not use the following detergents unless otherwise stated:**
 - **Detergents containing acetone**
 - **Detergents containing trichloroethylene**
 - **Detergents containing cresol soap (Lysol water)**
 - **Detergents containing phenolic compound base**
 - **Alkaline detergents**
 - **Acid detergents**
 - **Any frictional material, bleaching powder or strong solvent (e.g., acetone or detergent containing acetone)**
- **Do not use the following disinfectants or disinfection methods unless otherwise stated:**
 - **Disinfectant containing chlorine dioxide**
 - **Disinfectant containing trichloroisocyanuric acid**
 - **Disinfectant containing EtO (ethylene oxide)**

- Disinfectant containing peracetic acid
- Disinfectant containing benzalkonium bromide or benzalkonium chloride
- Disinfectant containing chlorhexidine gluconate or chlorhexidine acetate
- Disinfectant containing quaternary ammonium salt
- Disinfectant containing potassium persulfate
- Disinfectant containing potassium permanganate
- Iodophor or tincture of iodine
- Ozone disinfection
- High pressure steam disinfection
- High temperature disinfection
- Do not sterilize any accessory unless otherwise stated.
- Do not soak the device and accessories into any liquid.
- Do not pour any liquid onto any part or accessory of the device.
- Do not allow any liquid to flow into the housing.
- Dilute the detergent and disinfectant as specified by the manufacturer.
- Before cleaning the monitor, power it off and disconnect it from the AC power supply.
- Do not leave any disinfectant residue on the surface and accessory of the monitor. Use a wet cloth to clean it immediately.
- Avoid touching the metal connectors for avoiding corrosion when cleaning and disinfecting the device and its accessories.
- After cleaning, if the sensor cable is damaged or shows any evidence of ageing, it should be replaced with a new cable.



CAUTION

- 11.2 ● If you carelessly pour any liquid onto the device or any accessory, please contact the maintenance personnel or the company immediately.

Cleaning of the Monitor

The monitor should be kept clean. It is suggested that the external surface of the housing should be cleaned frequently; note that in environments with tough conditions or very windy and dusty places, the cleaning frequency should be increased. Before cleaning, first consult or understand the relevant rules of your hospital on equipment cleaning. Clean water and alcohol (75%) are recommended by our company.

Cleaning steps:

- 1) Power the equipment off, unplug the power cord and remove the batteries.

- 2) Use a soft cloth dipped with an amount of detergent to wipe the surface of the monitor. Avoid the interfaces and metal components.
- 3) If necessary, you can use a soft, dry cloth to remove residual detergent.
- 4) Put the monitor in a cool and well-ventilated environment to air-dry them.

Disinfection of the Monitor

11.3 It is suggested that the monitor can be disinfected only when it is considered necessary in the maintenance plan of your hospital. Before disinfection, clean the monitor and modules first. OPA (5.5g/L), 70% isopropanol, 70% n-propanol, 2% glutaraldehyde, 3% hydrogen peroxide and 0.5% sodium hypochlorite solution are recommended by our company.

Cleaning and Disinfection of Accessories

11.4

Please consult or understand the hospital's regulations regarding equipment cleaning before cleaning. Disinfection is recommended to disinfect accessories only when necessary in the hospital maintenance schedule. Before disinfecting the accessories, please clean them first.

11.4.1 Cleaning and Disinfection of Other Accessories

11.4.1.1 Cleaning of Accessories

Cleaning steps:

- 1) After using a soft cloth to absorb the proper amount of detergent, wipe the accessories
- 2) If necessary, use a soft dry cloth to wipe the surface of the accessories.
- 3) Place the accessories in a cool and ventilated environment to air-dry them.

The following table lists the recommended detergents:

Cleaning Parts	Detergent
US transducer, TOCO transducer, remote event marker and fetal stimulator	Clean water, 75% alcohol

11.4.1.2 Disinfection of Accessories

The following table lists the recommended disinfectant:

Cleaning and Disinfection

Cleaning Parts	Disinfectant
US transducer, TOCO transducer, remote event marker and fetal stimulator	OPA (5.5 g/L), 70% isopropanol, 70% n-propanol, 2% glutaraldehyde, 3% hydrogen peroxide and 0.5% sodium hypochlorite solution

Sterilization

11.5 Sterilization of the monitor, related products or accessories is not permitted unless otherwise specified in the accompanying instructions.

Chapter 12 Maintenance

Maintenance and Checks

Before use of the device, or every 6-12 months or after each maintenance or upgrade, a comprehensive check, including functional safety check, of the device should be carried out by qualified technical maintenance personnel having received training.

If you find any damage on the monitor, stop using it on patients, and contact the biomedical engineer of the hospital or the company immediately.

All the safety and maintenance checks that need to dismantle the monitor should be performed by a qualified maintenance technician. Non-professional disassembly/reassembly can cause the monitor damage or cause a security risk, and human health may be endangered.

Upon request by the user, Comen will conditionally provide relevant circuit diagrams to help the user to repair user-serviceable components of the device by appropriate and qualified technicians.



WARNING

- **The hospital or organization using this monitor should establish a sound maintenance plan; failure to do so may result in malfunction of the device and unpredictable consequences, and may also endanger personal safety.**
- **Before each use of the monitor, check the monitor, transducer and cables for damage that may endanger the patient's safety or reduce performance of the monitor.**
- **Always check the transducer assembly cables and their plugs before use and never use damaged cables and plugs.**
- **At the end of the monitor's service life, the monitor and its accessories must be disposed of in accordance with the local laws and hospital's regulations.**
- **Check the device and accessories periodically to avoid inaccurate measurement.**
- **The maintenance personnel should have certified qualifications and be familiar with the device.**
- **Dry the equipment immediately if it is exposed to rain or water spray and contact the maintenance personnel or the company.**
- **Do not maintain or repair the device during monitoring.**

Reusable Accessory Service Life

	Accessories	Service life
12.2	TOCO transducer	Two years
	US transducer	Two years
	Remote event marker	Two years
	Fetal stimulator	Five years

Maintenance Schedule

12.3 The following maintenance and test items can only be conducted by the maintenance personnel approved by Comen. Please clean and disinfect this monitor before maintenance and test.

Maintenance and test items	Schedule
Visual inspection	
Visual inspection	Before use every day
Safety inspection	
Perform safety inspection according to IEC 60601-1	<ol style="list-style-type: none"> 1. When the power module is maintained or replaced 2. After the monitor has been dropped 3. Once every two years or as required
Other inspections	
Power-on test	Before every use
Recorder test	<ol style="list-style-type: none"> 1. Before first use 2. When the recorder is maintained or replaced
12.4 Battery inspection	Refer to Chapter 10 Battery .

Testing Methods and Steps

All tests and maintenance work can be fulfilled only by professional maintenance personnel recognized by the Company except the following tasks.

- ◆ General inspection, including visual inspection and startup inspection
- ◆ Recorder inspection
- ◆ Battery inspection

If other maintenance is required, please contact the maintenance personnel immediately.

12.4.1 Visual Inspection

Inspect visually the appearance of the device before use every day. If any damage or malfunction occurs, stop using the device immediately and contact the hospital's equipment engineer or maintenance personnel authorized by Comen.

The following requirements should be satisfied:

- ◆ The environment and power supply comply with the specifications.
- ◆ The housing of the device should be kept clean, and the panel and the screen should not be cracked or damaged.
- ◆ The power cord shows no sign of wear and has good insulation.
- ◆ The connector, plug and cable show no sign of damage.
- ◆ Cables are well connected with the device and modules.

12.4.2 Startup Inspection

The monitor will perform a self-test after startup. The following requirements should be satisfied:

- ◆ The monitor can be turned on normally.
- ◆ The alarm system works normally.
- ◆ The indicator and the screen can be illuminated normally.

12.4.3 Recorder Inspection

- 1) Start to print the waveforms and reports through the recorder.
- 2) Check whether the recorder feeds paper normally.
- 3) Check whether the waveform and texts are legible.

12.4.4 Battery Inspection

Refer to *Section 10.3 Conditioning and Checking Battery Performance*.

12.4.5 Disposal of Monitor and Accessories

12.5

When the monitor and/or accessories reach the end of the service life, dispose of them in accordance with local laws and regulations.

Testing Ultrasound Transducers

See *Section 5.8.1 Testing Ultrasound Transducers* for details.

Testing TOCO Transducers

See *Section 5.9.1 Testing TOCO Transducers* for details.

12.6

Accessories

Here we recommend the following accessories for the device.



WARNING

Appendix I

- Use the accessories of the types designated by the manufacturer only, or the device may be damaged or performance may be affected.
- Please check the packaging of the accessories before using the accessories. Do not use the accessory if it is found to be damaged.
- Expired and damaged accessories may cause environmental pollution and must be disposed of in accordance with relevant local laws and regulations or hospital systems.
- This monitor and its supporting accessories have been tested for compliance with relevant standards.
- Before monitoring the patient, check the accessories are compatible with the monitor. Incompatible accessories reduce the performance of the monitor.

No.	Name	Model/Specification
1	Wired ultrasound transducer	CM-F01-001
2	Wireless ultrasound transducer	CM-F01-002
3	Wired TOCO transducer	CM-F02-001
4	Wireless TOCO transducer	CM-F02-002
5	Remote event marker	CM-F05-001
6	Fetal stimulator	CM-F03-001
7	Belt	5.5CM*1.5M
8	Belt	TJ028
9	Belt	TJ003
10	Belt	TJ003

Product Specifications

1. Monitor Type

Item	Type
Type of protection against electric shock	Class I device using external power supply; defibrillation-proof device with internal power supply
Level of protection against electric shock	CF: FHR1, FHR2, TOCO, MARK, EX1.1
Degree of protection by enclosure	Main unit: IPX0; US Transducer, TOCO Transducer: IP68
Degree of safety for flammable anesthetic mixture with air or oxygen or nitrous oxide	The equipment cannot be used within flammable anesthetic mixture with air or oxygen or nitrous oxide.
Mode of operation	Continuous operation
Whether contains signal output/input connections	Contains signal input or signal output connections
Permanent or non-permanent installation	Non-permanent installation

2. Monitor Specifications

(1) Dimensions and weight

Item	Specification
Size	Main unit: 305mm*232mm*84mm, tolerance ± 2 mm Wired/wireless ultrasound transducer: 76.2mm*89.4mm*20.5mm (without fixation cap)/ 29.5mm (with fixation cap), tolerance ± 1 mm Wired/wireless ultrasound transducer: 76.2mm*89.4mm*22.1mm (without fixation cap)/31.1mm (with fixation cap), tolerance ± 1 mm
Wight	Main unit: 3.1kg \pm 0.3Kg Wired ultrasound transducer: ≤ 150 g (not including the wire) Wired TOCO transducer: ≤ 150 g (not including the wire) Wireless ultrasound transducer: ≤ 150 g Wireless ultrasound transducer: ≤ 150 g

(2) Environmental specifications

Item	Specifications	
Working conditions	Ambient temperature	0°C ~ 40°C
	Relative humidity	15% ~ 95%, non-condensing

Product Specifications

	Barometric pressure	86Kpa ~ 106Kpa
Transportation and Storage conditions	Ambient temperature	-20°C ~ 60°C
	Relative humidity	15% ~ 95%, non-condensing
	Barometric pressure	70Kpa ~ 106Kpa

(3) Power specifications

Item	Specification
Power voltage	100-240V~
Power frequency	50Hz/60Hz
Input current	0.85-0.45A

(4) Display specifications

Item	Specification
Size	8 inch
Resolution	800*600

(5) Recording specifications

Item	Specification
Recording information	The waveforms and parameters output from the recording module should be consistent with the simultaneous information shown on the display.
Paper speed	<p>Fetal parameters</p> <p>The paper speed of the recorder shall be recorded legibly on the recorder paper.</p> <p>Paper speed: 3cm/min, 2cm/min and 1cm/min, error: ±5%</p> <p>The baseline drift of the built-in real-time recorder shall not be greater than 5% of the full range.</p>

(6) Monitor battery

Item	Specification
Battery specification	11.1V ⁻⁻⁻ 2200mAh; rechargeable Lithium-ion battery
Charging time	CF3/CF3A/CF30/CF30A/CF3R/CF3AR/CF30R/CF30AR: 11.1V ⁻⁻⁻ 2200mAh: When the monitor is turned off: it takes ≤ 4 hours to charge to 90%. When the monitor is turned on: it takes ≤ 5.5 hours to charge to 90%.
Operating time	<p>a) Fully charged CF3/CF3A/CF30/CF30A/CF3R/CF3AR/CF30R/CF30AR can operate for not less than 3 hours (Condition: installed with a new fully charged battery, at a temperature of 20°C – 30°C, performing monitoring when connected with a US transducer and TOCO transducer, real-time printing at the paper speed of 3cm/min and with level-1 screen brightness).</p> <p>b) The fully charged wireless transducer of CF3R/CF3AR/CF30R/CF30AR can operate for not less than 9 hours.</p>

(7) Transducer battery

Item	Specification
Battery specification	3.8V --- 1900mAh, rechargeable Lithium-ion battery
Charging mode	Wireless charging
Charging time	≤8 hours (standby or off status)
Operating time	≥9 hours

(8) Storage specification

Item	Specification
Data storage	a) The monitor data shall be stored once every 10 minutes. b) The storage duration of a single case is 24 hours, after which another case is formed. c) The monitor can store at least 500 files or 5000h of data.

(9) FHR specification

Item	Specification
Meets the requirements of ICS 11.040.50	
Pulse repetition rate	(2±10%) KHz
Pulse duration	(92±10%) μs
Ultrasound frequency	(1±10%) MHz
FHR ultrasound signal range	3.5μV Vpp ~ 350μV Vpp
Peak negative acoustic pressure	P ₋ <1MPa
Intensity of output beam	I _{ob} <3.5mW/cm ²
Spatial peak-temporal average intensity	I _{spta} <100mW/cm ²
Spatial average temporal average intensity	I _{sata} <3.5mW/cm ²
Derated spatial-peak pulse-average intensity	I _{sppa.3} <190mW/cm ²
Derated spatial-peak temporal-average intensity	I _{spta.3} <94mW/cm ²
Maximum output power	<15mW
Effective radiating area	1000mm ² ±15%
FHR measurement and display range	50bpm ~ 240bpm
FHR measurement accuracy	±2bpm
Resolution	1bpm

Temperature rise	When applied to the patient, the temperature of the ultrasound transducer may rise slightly (less than 10 °C above the ambient temperature). When not applied to the patient, the temperature of the ultrasound transducer may rise slightly (less than 10 °C above the ambient temperature).
FHR alarm	The device can generate continuous alarm signal. It takes not greater than 30s to start the FHR alarm after the FHR exceeds the alarm limits.
FHR alarm range and error	Alarm range: 50bpm ~ 240bpm Error: ±1bpm
Breakpoint continuation (only applicable to CF3 R/CF3A R/CF30 R/CF30A)	The monitor can continue to transmit the data for at most 15 minutes in case of disconnection, to ensure the continuity of monitoring data in a harsh wireless environment.
One-click transfer	Supports one click bed transfer

(10) Acoustic output report

Index Label		MI	TIS		TIB		TIC
			At surface	Below surface	At surface	Below surface	
Maximum index value		0.022	0.036		0.150		--
Index component value			0.036	0.011	0.150	0.068	
Associated Acoustic Parameters	$p_{r,a}$ at z_{MI} (MPa)	0.022					
	P (mW)		6		6		--
	$P_{1 \times 1}$ (mW)		7.640		7.640		
	z_s (cm)			2.0			
	z_b (cm)					2.0	
	z_{MI} (cm)	2.0					
	$Z_{pii,a}$ (cm)	2.0					
	f_{awf} (MHz)	1.000	1.000		1.000		--
Other Information	pr (Hz)	2000					
	srr (Hz)	1					
	n_{pps}	1					
	$I_{pa,a}$ at $Z_{pii,a}$ (W/cm^2)	0.011					
	$I_{spta,a}$ at $Z_{pii,a}$ or $Z_{sii,a}$ (mW/cm^2)	2.221					
	I_{spta} at Z_{pii} or Z_{sii} (mW/cm^2)	2.550					
	p_r at Z_{pii} (MPa)	0.024					
System	Depth	2cm					

Product Specifications

Setup	Focus	2cm
	/	/
	/	/
	/	/

Index Label	MI	TIS		TIB		TIC	
		At surface	Below surface	At surface	Below surface		
Maximum index value	0.029	0.158		0.650		--	
Index component value		0.158	0.015	0.650	0.168		
Associated Acoustic Parameters	$p_{r,a}$ at z_{MI} (MPa)	0.029					
	P (mW)		26		26		--
	$P_{1 \times 1}$ (mW)		33.105		33.105		
	z_s (cm)			2.0			
	z_b (cm)					2.0	
	z_{MI} (cm)	2.0					
	$Z_{pii,a}$ (cm)	2.0					
	f_{awf} (MHz)	1.000	1.000		1.000		--
Other Information	pr (Hz)	2000					
	srr (Hz)	1					
	n_{pps}	1					
	$I_{pa,a}$ at $Z_{pii,a}$ (W/cm^2)	0.017					
	$I_{spta,a}$ at $Z_{pii,a}$ or $Z_{sii,a}$ (mW/cm^2)	3.113					
	I_{spta} at Z_{pii} or Z_{sii} (mW/cm^2)	3.573					
	p_r at Z_{pii} (MPa)	0.031					
System Setup	Depth	2cm					
	Focus	2cm					
	/	/					
	/	/					
	/	/					

(11) TOCO

Item	Specification
TOCO range	0 unit ~ 100 unit
Non-linear error	±10%
Baseline drift due to	≤1 unit/min/°C (in the air)

Product Specifications

temperature changes	≤5 units/min/°C (under water)
Resolution	1 unit
Zero mode	Automatic (TOCO value becomes 0 automatically if the measurement value is 0 for 30s.), Manual

(12) Fetal movement

Item	Specification
FM mode	Manual or Automatic (only applicable to FHR 1.)
Automatic FM mode	Trace or Black Mark
Display range	0~999

(13) Fetal stimulator (applicable to CF3/CF30/CF3R/CF30R)

Item	Specification
Fast mode (Fast)	Vibration duration: 0.2s, vibration cycle: 1.4s (frequency 0.714Hz)
Slow mode (Slow)	Vibration duration: 0.8s, vibration cycle: 2s (frequency 0.5Hz)
Manual mode	The Fast or Slow mode vibrates for 3 cycles and then stops.

(14) Wi-Fi Specification

Item	Specification	
Main unit Wi-Fi module	Standard	IEEE 802.11 a/b/g/n
	Frequency band	2.4G & 5G
	Distance	Visibility > 20m (the architecture structure and materials define the indoor distance)
Transducer Wi-Fi module	Standard	IEEE 802.11 a/b/g/n
	Frequency band	2.4G & 5G
	Distance	Visibility > 20m (the architecture structure and materials define the indoor distance)
NFC Specification	Working frequency	13.56MHz

System Alarm Information

Some of the most important physiological and technical alarm messages are listed in this section, and some of the alarm information may not be listed.

The corresponding countermeasures are listed for the alarm information. After following the countermeasures, if the problem persists, please contact maintenance personnel.

1. Physiological alarms

Source	Default level	Adjustable level	Cause	Countermeasures
FETAL				
FHR Too High	Med	High, Med, Low	The value of the measured parameter is above the upper alarm limit or below the lower alarm limit.	Check the patient's physiological condition, and confirm if alarm limit settings are appropriate for the patient.
FHR Too Low	Med	High, Med, Low		
TOCO Too High	Med	High, Med, Low		
CTG Score				
FHR Low Variability	Med	Not adjustable	18-minute variability ≤ 2 bpm within 20 min	Check the conditions of the patient and the fetus.
FHR PD	Med	Not adjustable	PD > 0 within 9 min	
FHR Sinusoidal Pattern	Med	Not adjustable	Sinusoidal FHR pattern is present for 15min in the last 20 min.	
FHR No Variable Tachycardia	Med	Not adjustable	Tachycardia with 9-minute variability ≤ 2 bpm within 10 min	
FHR Suspected PD	Med	Not adjustable	PD was detected when MHR is similar with FHR and PD > 0 in 9min	
FHR Low Variability, No Variable Tachycardia	Med	Not adjustable	18-minute variability ≤ 2 bpm within 20 min, and tachycardia with 9-minute variability ≤ 2 bpm within 10 min	
FHR No Variable Tachycardia, PD	Med	Not adjustable	Tachycardia with 9-minute variability ≤ 2 bpm within 10 min, and PD > 0 within 9 min	
FHR No Variable Tachycardia, Suspected PD	Med	Not adjustable	Tachycardia with 9-minute variability ≤ 2 bpm within 10 min, PD was detected when MHR is similar with FHR and PD > 0 in 9min	

2. Technical alarms

This section lists some technical alarms, their alarm levels, clearance methods, causes and countermeasures. Some of the alarm information may not be listed.

XX stands for: certain module names and physiological parameters in the FHR1, FHR2, TOCO and other systems. After the alarm is reset, the technical alarms will be cleared in different ways. These alarms are classified into 3 categories, A for fully clearable, B for partially clearable (the sound and light) and C for not clearable.

- Fully clearable: Technical alarms is completely cleared.
- Partially (the sound and the light) clearable: Technical alarms are shown as text messages.
- Not clearable: The sound of the technical alarms is cleared, and the V sign in front of the text message indicates alarms acknowledged.

Source	Alarm Message	Level	Type	Cause	Countermeasures
XX	XX Init Error	High	A	Error X occurs during initialization of XX module.	Reboot and try again. If the error persists, contact the manufacturer for repair.
	XX Comm Stop	High	C	The XX module cannot communicate with the main system.	
	XX Comm Error	High	A	The XX module cannot communicate normally with the main system.	
XX	XX Overrange	High	C	The measured value of the XX parameter is beyond the measurement range that the system can perform.	Contact the manufacturer for repair.
FHR	Adjust Transducer Position	High	C	The US transducer may have detected MHR.	Adjust the position of US transducers.
	FHR1 Probe Off	Low	B	FHR1 transducer is not connected.	Check the FHR1 transducer.
	FHR2 Probe Off	Low	B	FHR2 transducer is not connected.	Check the FHR2 transducer.
	FHR1 Signal loss	High	C	The transducer is not connected or not placed correctly, or the device malfunctions.	Check the patient's current conditions, and confirm that the transducer is connected and placed correctly. If there is device error, contact the manufacturer for repair.
	FHR2 Signal loss	High	C		
	FHR1 Poor Signal	High	C	The transducer is not placed correctly or is interfered, and cannot detect the FHR.	Check the patient's current conditions and replace the transducer.
	FHR2 Poor Signal	High	C		
	FHR1 Weak Signal	High	C	The data of the FHRx channel is out of the range of 50-240. The fetal board generates the alarm of weak signal.	Contact the manufacturer for repair.
FHR2 Weak Signal	High	C			

System Alarm Information

Source	Alarm Message	Level	Type	Cause	Countermeasures
	FHR1 Poor Wireless Signal	High	C	The transducer is not placed correctly or is interfered. The transducer cannot detect the FHR due to transmission distance.	Check the patient's current conditions. Confirm that the transducer is placed correctly within the transmission distance.
	FHR2 Poor Wireless Signal	High	C		
TOCO	TOCO Probe Off	Low	B	TOCO transducer is not connected.	Check the TOCO transducer
	TOCO Poor Wireless Signal	High	C	The transducer is not placed correctly or is interfered. The transducer cannot detect TOCO due to transmission distance.	Check the patient's current conditions. Confirm that the transducer is placed correctly within the transmission distance.
Others	Low Battery	Med	C	The battery is lower than 20% but more than 15%.	Connect to the mains supply and charge the battery. If the problem persists after the battery is charged for 6h, contact the manufacturer for repair.
	Battery is critically low	High	C	The battery is lower than 15% but more than 10%.	Connect to the mains supply and charge the battery. If the problem persists after the battery is charged for 6h, contact the manufacturer for repair.
	Recorder Door Open	Low	C	The recorder door is not closed.	Close the recorder door.
	Recorder Head Hot	Low	C	The recorder is printing for a long time.	Stop printing and wait until it cools down.
	No Record Paper	Low	C	The recorder is out of paper.	Check the recorder and load the paper.
	Recorder Selftest Error	Low	C	Recorder Failure	Restart and check the recorder is intact. Contact the manufacturer for repair if required.
	No Recorder Connected	Low	C	The recorder module is not connected.	Insert the recorder module.
	Recorder Error	Low	C	The recorder module fails.	If there is any fault, contact the manufacturer for repair.
	OB Disconnected	Low	B	The monitor is disconnected from the CMS.	Check if the server IP and device IP are corrected, and if the Starting Monitoring hotkey is pressed to monitor the patient.
	OB Connection Conflict	Low	B	Different monitors with the same net bed number are connected to the CMS at the same time.	Check if the net bed number is duplicate.

3. Prompts

Source	Prompt Message	Level	Cause
Fetal	Module Alarm Disabled	None	/
	TOCO Zero Succeeded	None	/
	TOCO Zero Failed	None	/
	TOCO Probe is not Calibrated to Zero	None	/
	TOCO Zeroing	None	/
	TOCO Zero Succeeded	None	/
	TOCO Zero Failed	None	/
	TOCO Calibration Value Overrange	None	/
Others	Demo	None	/
	Night Mode	None	Enter the night mode
	MAC Conflict	None	/
	IP Conflict	None	/
	No printing paper	None	No paper during printing
	Printer busy	None	/
	No Printer Toner	None	/
	Printer Door Open	None	The printer door is open.
	Printer Error	None	Error occurs in the printer.
	USB Printer Not Support	None	/
	Net Printer Not Support	None	/
	Exporting	None	Patient file is being exported.
	USB Drive Full	None	There is no enough space in the USB drive.
	USB Drive Write Error	None	/
	USB Drive Removed	None	The USB drive is removed.
	Data exported successfully	None	The patient data has been successfully exported.
	Failed to export data	None	Patient data is not exported.
	USB drive not recognized.	None	The USB drive is not recognized.
	Language pack imported	None	Import the language pack
	Failed to import configuration	None	Configurations are not imported.
Import configuration succeeded	None	Configurations have been successfully imported.	
Reboot the device	None	/	
Failed to export log	None	/	

System Alarm Information

Source	Prompt Message	Level	Cause
	Export Log succeeded	None	/
	Collecting data.....	None	Data is being collected.
	Recording...	None	The waveform reports are being recorded.
	Printing... Connect the power supply.	None	The battery is low during printing.

Default Configuration

The following lists the configuration and some of the most important factory default settings in the monitor. The user cannot change the default configurations, but can change the settings as required and save them as custom configuration.

Appendix IV

1. General Setup

(1) Volume

Item	Default Settings
QRS Volume	2
Alarm Volume	2
Key Volume	2
Reminder Volume	2

(2) Screen Brightness

Item	Default Settings
Brightness	3

(3) Unit

Item	Default Settings
Height Unit	cm
Weight Unit	kg

(4) Module Color

Item		Default Settings	
		Space Dark	Silence Whit
Waveform/Parameter Color	FHR1	Sky blue	Deep sea blue
	FHR2	Light dark pink	Dark blue
	TOCO	Orange	Brown
	FM	Pink	Dark pink

(5) Screen Color

Item	Default Settings
Screen Color	Space Dark

(6) Patient Information Review

Item	Specifications
Create a new patient file	Press the Start Monitoring shortcut key to create a new patient file.
Date storage frequency	Update once every 10 minutes (The fetal waveform will be updated to the patient file.)
Storage of a single file	The storage duration of a single file is 24 hours, after which another case is formed.
Storage limit	Up to 500 patient files or date of 5000 hours

(7) Layout

Item	Default Settings
Main Screen	Fetal Screen
Waveforms on the standard screen	1 FHR1
	2 FHR2
	3 TOCO/MARK

(8) Record Setup of Fetal Parameters

Item	Default Settings
Paper Speed	3cm/min
Duration	20min
Print Self-test	OFF
End Tone	OFF
End Volume Level	Low
FHR2 Offset	0bpm
Title Print Interval	10min
Separation Print	OFF
Data Caching	OFF
Print CTG Score	OFF
Fetal Analysis	OFF
Fetal Analysis Channel	FHR1

2. Default Setup

(1) FHR1/2

Item	Default Settings
Alarm Switch	ON

Default Configuration

Alarm Level	Med
Alarm Limit	110-160
Upper Limit Alarm Delay	10 s
Lower Limit Alarm Delay	10 s
Signal Loss Alarm Delay	10 s (only applicable to wireless transducers)
Weak Signal Alarm	OFF
Probe Off	OFF (only applicable to wireless transducers)

(2) TOCO

Item	Default Settings
Alarm Switch	ON
Alarm Level	Med
Alarm Limit	0-90
UA Baseline	10
Probe Off	OFF (only applicable to wireless transducers)

(3) FM

Item	Default Settings
FM Volume	2
AFM	Med
FM Source	Manual
AFM Mode	Trace

(4) CTG

Item	Default Settings
Paper Speed	3cm/min
FHR2 Offset	0bpm

(5) Fetal Setup

Item	Default Settings
FM Volume	2
AFM	OFF
FM Source	Manual
AFM Mode	Trace
UA Baseline	10

Default Configuration

CTG Score	OFF
Smart Notes	OFF
Cross Duration	30s
Cross Error	5bpm

(6) Monitoring Setup

Item	Default Settings
Fetal Volume	0
Auto Print	OFF
Patient Information	OFF

3. User Maintenance

(1) Date and Time

Item	Default Settings
Date	Current system time
Time	Current system time
Date Format	YYYY-MM-DD
24-Hour Time	OFF

(2) Alarm

Item	Default Settings
Volume	
Minimum Alarm Volume	2
Auto Increase Volume	OFF
Increase Volume Delay	30s
Pause/Reset	
Pause	Alarm Pause
Pause Time	2min
Alarm Light	On When Reset
Alarm Reset Reminder	ON
Alarm Off Reminder	ON
Other	
CMS Alarm System Control	ON

Default Configuration

(3) Network Setup

Item	Default Settings
Network Protocol	
Network Protocol	CMS Protocol
Network Type	Wired
Wired Network	
IP Address	200.200.200.100
Subnet Mask	255.255.255.0
Gateway	200.200.200.1
Modify MAC Address	OFF
CMS	
Network Bed No.	1
Server IP	200.200.200.100
Modify Server Port	OFF

(4) Language Setup

Item	Default Settings
Language	English

(5) Scanner Setup

Item	Default Settings
Synchronize to	Patient ID

(6) Demo Mode

Item	Default Settings
Demo Mode	OFF

**NOTE**

- CF3/CF3A/CF30/CF30A/CF3 R/CF3A R/CF30 R/CF30A R Specified Fetal & Maternal Monitor complies with the applicable EMC requirements in IEC 60601-1-2 and IEC 60601-2-37.
- Please follow the EMC instructions in the User's Manual to install and use the device.
- Portable and mobile RF communication equipment may affect the performance of CF3/CF3A/CF30/CF30A/CF3 R/CF3A R/CF30 R/CF30A R Specified Fetal & Maternal Monitor. To protect the ventilator against strong electromagnetic interference, please keep it away from mobile phones, microwave ovens, etc.
- Refer to the attached guide and manufacturer's statement.
- CF3/CF3A/CF30/CF30A/CF3 R/CF3A R/CF30 R/CF30A R Specified Fetal & Maternal Monitor containing magnetically sensitive components or circuitry where a separation distance of those components or circuitry of at least 0.15m from the specified field sources is ensured by the enclosure or by the physical design of an attached accessory during intended use need not to be evaluated further for immunity to proximity magnetic fields in the frequency range 9kHz to 13.56MHz.

**WARNING**

- Do not stack CF3/CF3A/CF30/CF30A/CF3 R/CF3A R/CF30 R/CF30A R Specified Fetal & Maternal Monitor on/under or get it close to any other equipment. If you have to use it this way, observe and verify whether it works properly in such conditions first.
- CF3/CF3A/CF30/CF30A/CF3 R/CF3A R/CF30 R/CF30A R Specified Fetal & Maternal Monitor may still be subject to interference from other devices, even if they meet the emission requirements of the applicable national standards.
- This equipment is not intended for use in residential environments where adequate protection for radio reception is not available.
- Using any accessory or cable other than sold by the manufacturer as spare parts may cause higher electromagnetic emission or lower electromagnetic immunity.
- Running the device with the value below the minimum amplitude or minimum value specified in this manual may lead to inaccurate results.
- Using any accessory or cable other than specified by the manufacturer with the device may cause higher electromagnetic emission or lower electromagnetic immunity.

Transmitting frequency or frequency band, modulation type and frequency characteristics and effective radiation power table.

Wireless frequency band type and effective radiation power table (only applicable to CF3 R/CF3A R/CF30 R/CF30A R)

Type	Wireless transducer	Wireless main unit
Transmission frequency	IEEE802.11b/g/h (2.4G):2.412GHz~2.472GHz IEEE802.11a (5G):5.18 GHz~5.24GHz, 5.745 GHz~5.825 GHz,	IEEE802.11g/n/ac(2.4G): 2.412GHz~2.472GHz IEEE802.11a/n/ac(5G): 5.18 GHz~5.825 GHz
Modulation type	IEEE802.11 a/b/g/h	IEEE802.11 a/c
Frequency characteristic	IEEE802.11b/g/h (2.4G):2400MHz~2500MHz IEEE802.11a (5G):4900MHz~5845MHz	IEEE802.11g/n/ac(2.4G): 2400MHz~2500MHz IEEE802.11a/n/ac(5G): 4400MHz~5000MHz
Radiation power	IEEE802.11b/g/h (2.4G):17.98 dBm IEEE802.11a (5G):12.68 dBm	IEEE802.11n/ac(2.4G):21.5dBm IEEE802.11a(5G):13.5 dBm

Cable list:

No.	Item	Length (m)	With shielding
1	Power cord	3	No
2	6mm grounding post grounding wire	3	No
3	Remote event marker	3	No
4	Fetal stimulator	2	No
5	Ultrasound transducer	2.5	Yes
6	TOCO transducer	2.5	Yes

Essential performance:

1. Fetal heart rate measurement accuracy (± 2 bpm)
2. TOCO measurement accuracy (non-linear accuracy: $\pm 10\%$)
3. Do not use the device with high frequency surgical equipment.
4. Do not produce waveform noise, image artifacts or distortion, or displayed value error that may be attributed to physiological effects and that may alter the diagnostic results.
5. Do not display incorrect values related to the diagnosis being performed.
6. Do not produce incorrect indication related to safety instructions.
7. Do not produce unexpected or excessive ultrasound output.
8. Do not produce unexpected or excessive temperature rise of the transducer assembly.
9. The transducer assembly intended for internal use cannot move unexpectedly or uncontrollably.

Table 1:

Guidance and manufacturer's declaration– Electromagnetic Emission		
The CF3/CF3A/CF30/CF30A/CF3 R/CF3A R/CF30 R/CF30A R Specified Fetal & Maternal Monitor is intended for use in the electromagnetic environment specified below, and the customer purchaser or user of the CF3/CF3A/CF30/CF30A/CF3 R/CF3A R/CF30 R/CF30A R Specified Fetal & Maternal Monitor should assure ensure that it is used in such an environment.		
Emission Test	Compliance	Electromagnetic Environment – guidance
RF emission CISPR 11	Group 1	The CF3/CF3A/CF30/CF30A/CF3 R/CF3A R/CF30 R/CF30A R Specified Fetal & Maternal Monitor uses RF energy for its internal functions only. Therefore, its RF emission are low and do not cause interference to nearby electronic devices.
RF emission CISPR 11	Class A	The CF3/CF3A/CF30/CF30A/CF3 R/CF3A R/CF30 R/CF30A R Specified Fetal & Maternal Monitor is suitable for use in all establishments other than domestic and those directly connected to the public low-voltage power supply network that supplies buildings used for domestic purposes.
Harmonic emission IEC 61000-3-2	N/A	
Voltage fluctuation/ flicker emission IEC 61000-3-3	N/A	

Table 2:

Guidance and manufacturer's declaration– Electromagnetic Immunity			
The CF3/CF3A/CF30/CF30A/CF3 R/CF3A R/CF30 R/CF30A R Specified Fetal & Maternal Monitor is intended to for use the electromagnetic environment specified below, and the customer or user of CF3/CF3A/CF30/CF30A/CF3 R/CF3A R/CF30 R/CF30A R Specified Fetal & Maternal Monitor should assure that it is used in such an environment.			
Immunity Test	IEC 60601-1-2 test level	Compliance level	Electromagnetic Environment – guidance
Electrostatic discharge (ESD) IEC61000-4-2	Contact discharge: ±8kV Air discharge: ±15kV	Contact discharge: ±8kV Air discharge: ±15kV	Floors should be wood, concrete or ceramic. If floors are covered with synthetic material, the relative humidity should be at least 30%.

EFT IEC61000-4-4	To power cord: $\pm 2\text{kV}$ To input/output wire: $\pm 1\text{kV}$	To power cord: $\pm 2\text{kV}$ To input/output wire: $\pm 1\text{kV}$	Mains power quality should be that of a typical commercial or hospital environment.
Surge IEC61000-4-5	Differential-mode voltage: $\pm 1\text{kV}$ Common-mode voltage: $\pm 2\text{kV}$	Differential-mode voltage: $\pm 1\text{kV}$ Common-mode voltage: $\pm 2\text{kV}$	
Voltage sag, short interruption and voltage change on mains input wire IEC61000-4-11	0% U_T for 0.5 cycle: 0°, 45°, 90°, 135°, 180°, 225°, 270° and 315°	<5% U_T , duration = 0.5 cycle (U_T sag >95%)	Mains power quality should be that of a typical commercial or hospital environment. If the user of the CF3/CF3A/CF30/CF30A/CF3 R/CF3A R/CF30 R/CF30A R Specified Fetal & Maternal Monitor requires continued operation during power mains interruptions, it is recommended that the CF3/CF3A/CF30/CF30A/CF3 R/CF3A R/CF30 R/CF30A R Specified Fetal & Maternal Monitor be powered from an uninterruptable power supply or battery.
	40% U_T for 1 cycle, single-phase: 0°	40% U_T , duration = 5 cycles (U_T sag = 60%)	
	70% U_T for 25/30 cycles, single-phase: 0°	70% U_T , duration = 25 cycles (U_T sag = 30%)	
	0% U_T for 250/300 cycles	<5% U_T , duration = 5s (U_T sag >95%)	
Power frequency magnetic field IEC 61000-4-8	30A/m; 50/60Hz.	30 A/m 50/60Hz.	Power frequency magnetic fields should be at levels characteristics of a typical commercial or hospitals environment.
Note: U_T refers to the AC mains voltage prior to application of the test level.			

Table 3:

Guidance and manufacturer's declaration – Electromagnetic Immunity			
The CF3/CF3A/CF30/CF30A/CF3 R/CF3A R/CF30 R/CF30A R Specified Fetal & Maternal Monitor is intended for use in the electromagnetic environment specified below, and the customer or user of CF3/CF3A/CF30/CF30A/CF3 R/CF3A R/CF30 R/CF30A R Specified Fetal & Maternal Monitor should assure that it is used in such an environment.			
Immunity Test	IEC 60601 Test Level	Compliance Level	Electromagnetic Environment –guidance
RF conduction IEC 61000-4-5	3 Vrms 150 kHz to 80	3Vrms	Portable and mobile RF communication equipment should not be used closer to any part of CF3/CF3A/CF30/CF30A/CF3 R/CF3A R/CF30 R/CF30A R Specified Fetal & Maternal Monitor, including its cables, other than at the recommended separation distance calculated from the equation applicable to the transmitter frequency of the transmitter.

<p>RF radiation IEC 61000-4-3</p>	<p>MHz 3 V/m 80 MHz to 2.7 GHz</p>	<p>3 V/m</p>	<p>Recommended separation distance:</p> $d = [3.5 / V] \sqrt{P}$ $d = [0.35 / E1] \sqrt{P} \text{ 80 MHz to 800 MHz}$ $d = [7 / E1] \sqrt{P} \text{ 800 MHz to 2.7 GHz}$ <p>Wherein, P is the maximum output power rating of the transmitter in watts (W) according to the transmitter manufacturer; d is the recommended separation distance in meters (m).</p> <p>Field strengths from fixed RF transmitters, as determined by an electromagnetic site survey, ^a should be less than the compliance level in each frequency range^b.</p> <p>Interference may occur in the vicinity of equipment marked with the following symbol:</p> 
<p>Note 1: At 80 MHz and 800 MHz, the higher frequency range applies.</p>			
<p>Note 2: These guidelines may not apply to all situations. Electromagnetic propagation is affected by absorption and reflection from structures, objects and people.</p>			
<p>a For strengths from fixed RF transmitters, such as base stations for radio (cellular/cordless) telephones and land mobile radios, amateur radio, AM (amplitude modulation) and FM (frequency modulation) radio broadcasts and television broadcast, cannot be predicted theoretically with accuracy. To assess the electromagnetic environment due to fixed RF transmitters, an electromagnetic site survey should be considered. If the measured field strength in the location in which CF3/CF3A/CF30/CF30A/CF3 R/CF3A R/CF30 R/CF30A R Specified Fetal & Maternal Monitor is used exceeds the applicable RF compliance, the CF3/CF3A/CF30/CF30A/CF3 R/CF3A R/CF30 R/CF30A R Specified Fetal & Maternal Monitor should be observed to verify normal operation. If abnormal performance is observed, additional measures may be necessary, such as reorienting or relocating the CF3/CF3A/CF30/CF30A/CF3 R/CF3A R/CF30 R/CF30A R Specified Fetal & Maternal Monitor.</p> <p>b Over the frequency range 0.15 MHz to 80 MHz, field strengths should be less than 3V/m.</p>			

Table 4:

Recommended separation Distance between Portable and Mobile RF Communication Equipment and CF3/CF3A/CF30/CF30A/CF3 R/CF3A R/CF30 R/CF30A R Fetal & Maternal Monitor			
The CF3/CF3A/CF30/CF30A/CF3 R/CF3A R/CF30 R/CF30A R Specified Fetal & Maternal Monitor is intended for use in an electromagnetic environment where radiated RF disturbances are controlled. The customer or user of the Specified Fetal & Maternal Monitor can help prevent electromagnetic interference by maintaining a minimum distance between the portable and mobile RF communication equipment (transmitters) and the Specified Fetal & Maternal Monitor as recommended below, according to the maximum output power of the communication equipment.			
Rated Maximum Output Power of transmitter (W)	Separation Distance according to Frequencies of transmitter /m		
	150kHz~80MHz $d = 1.2\sqrt{P}$	80MHz~800MHz $d = 1.2\sqrt{P}$	800MHz~2.7GHz $d = 2.3\sqrt{P}$
0.01	0.12	0.12	0.23
0.1	0.38	0.38	0.73
1	1.2	1.2	2.3
10	3.8	3.8	7.3
100	12	12	23
For transmitters rated at a maximum output power not listed above, the recommended separation distance d , in meters (m), can be estimated using the equation applicable to the frequency of the transmitter, where P is the maximum output power rating of the transmitter in watts (W) according to the transmitter manufacturer.			
Note 1: At 80MHz and 800MHz frequencies, the separation distance for the higher frequency range applies.			
Note 2: These guidelines may not apply in all situations. Electromagnetic propagation is affected by absorption and reflection from structures, objects and people.			

Abbreviation and Terms

Abbreviation	Full Name
MHR	Maternal heart rate
AFM	Auto fetal movement
MFM	Manual fetal movement
BPM	Beat per minute
FHR	Fetal heart rate
HR	Heart Rate
TOCO	Tocography

Limitations of Ultrasound Monitoring

1. The principle of ultrasound monitoring

The ultrasound wave will reflect when it encounters an object, when the object moves toward the sound source, the frequency of the reflected wave becomes higher; when the object moves away from the sound source, the frequency of the reflected wave decreases. This phenomenon is called the Doppler Effect.

During fetal monitoring, place an ultrasonic transducer on the measurement site and it emits high-frequency sound wave into the maternal abdomen. It can be reflected to the transducer if the ultrasound wave strikes an organ, and the movement of organs produces the Doppler Effect. The movement of organs can be depicted by measuring the reflected waves.

The sound waves emitted by the ultrasonic transducer penetrate the mother's abdomen and are reflected back by the fetal heart. Then the transducer receives the echoes and transfers them to the monitor, which turns the signal into fetal heart sound and fetal heart rate trace.

2. Artifacts in fetal heart monitoring.

(1) The generation of artifacts

The probe detects sound waves reflected from the fetal heart, but the sound waves reflected from the mother's blood vessels may also be received and processed, resulting in artifacts.

If these artifacts are not properly discerned, it is very likely that the medical staff will perform some unnecessary interventions or fail to detect fetal distress without the necessary intervention.

The most common artifacts are doubling or halving.

(2) Doubling

When the fetal heart rate drops to 120 bpm or lower, the diastolic and contraction intervals of the heart become so long that it is possible for the monitor to interpret the two heart movements of one heartbeat as two separate heart beats. This produces a heart rate curve that doubles to the actual heartbeat. This phenomenon generally occurs during periods of severe deceleration and bradycardia, as the heart rate trace suddenly switches to double the actual heart rate values.

(3) Halve

When the fetal heart rate rises, the diastolic and contraction intervals of the heart become so short that it is possible for the monitor to interpret the two separate heartbeats as two heart movements of one heartbeat. This produces a heart rate trace that is half the actual heart rate. This phenomenon usually occurs during tachycardia, and the heart rate curve suddenly switches to half of the actual heart rate value, which the physician may consider to be a "deceleration."

However, when the doubling or halving occurs, the fetal heart sound emitted by the monitor is still reliable. Therefore, **when a sudden change in the baseline value occurs, the result of the auscultation should prevail.**

(4) Maternal-Fetal Heart Rate Coupling

Maternal-fetal heart rate coupling occurs most often in the second stage of labor. Abdominal muscle contraction due to abdominal pressure and uterine contractions affects the acquisition of the fetal heart signal. Tachycardia, higher MHR close to or reaching the FHR, and signals from aorta or other large vessels may be taken as FHR.

(5) Erratic Traces / Drop out

Excessive contractions, frequent fetal movement and maternal activity may change the position of the transducer and the fetal heart. Weak fetal heart signal, even no signal, can be obtained. Therefore, the fetal heart traces are erratic or even disappear.

Erratic trace and short-term drop out are common. However, if this condition persists for a long time, it indicates that the transducer does not aim at the fetal heart and the transducer should be repositioned.

3. Audio output and screen display.

Generally, the fetal heart sound output by the monitor corresponds to the FHR traces and values displayed on the screen.

If the fetal heart moves outside the ultrasound wave path, weaker fetal heart rate signal will be received and there will be strong interfering signal, which is usually the maternal heart rate. After the monitor obtains the mixture of signals, the monitor filters out the lower frequency mother signal and outputs a high frequency fetal heart rate signal (i.e., the fetal heart rate). A strong maternal signal calculated through the monitor's algorithm shows the maternal heart rate.

This situation does not happen often. If it does, it can be eliminated by adjusting the transducer position.

If there is any doubt about fetal monitoring, please contact the manufacturer.

Mechanical Index (MI) and Thermal Index (TI)

The thermal and mechanical mechanisms of the biological effects of ultrasound have been widely concerned and generally recognized by the academic community, combined with the requirements of the IEC60601-2-37, **Appendix VIII** MI (mechanical index) and TI (thermal index) of medical ultrasound diagnostic equipment are explained below for the better understanding the user.

In the process of propagation of ultrasound in biological system, its vibration energy is continuously absorbed by the medium and converted into heat energy to increase its own temperature. If the sound wave also causes the biological system to produce a certain effect, with other heating methods to obtain the same temperature rise, and repeat the same effect. The cause of the biological effect is the thermal mechanism.

The value of MI (mechanical index) is used as an indicator of the mechanical mechanism of ultrasound (e.g. cavitation). It is used to estimate the potential for mechanical biological effects. Examples of mechanical effects include the movement of ultrasound pressure waves around compressible bubbles as they penetrate biological tissues and the release of energy through the disintegration of transient bubbles by the cavitation phenomenon. MI is intended to give an indication of the potential risk of ultrasound mechanical effects such as cavitation.

TI (thermal index) is the ratio of the attenuated acoustic power value at a defined point to the attenuated acoustic power value required to increase the tissue temperature at that point by 1 degree. TI is divided into TIB, TIS, and TIC depending on the thermal physical properties of the tissue:

TIS: Soft Tissue Thermal Index, used to assess the temperature rise within soft tissue or similar tissues.

TIB: Bone Thermal Index, used to assess the temperature rise within the ultrasound through soft tissue or similar tissues.

TIC: Cranial-bone Thermal Index, used to assess the temperature rise within the skull or superficial bones, such as the skull.

TI indicates the potential temperature rise at a particular point along the direction of the ultrasound beam.

Since the actual temperature rise of ultrasound is complex and varies with the human tissue and the working conditions of the equipment, an increase in TI value does not necessarily indicate the actual temperature rise, but the operator should be aware that the tissue temperature is going up and pay attention to it in the clinical diagnosis.

The clinical use of medical ultrasound diagnostic equipment must follow the principle of "ALARA" (As Low As Reasonable Achievable), that is, when obtaining the necessary clinical information, use the lowest possible ultrasound output level in the shortest possible radiation time to reduce the risk of using the device.

Prudent Use Statement

Although no side effects on patients or operators in terms of the intensity of ultrasound acoustic energy output required for the operation of diagnostic ultrasound instruments have been reported, it is still possible that such biological effects may be found in the future. Therefore, ultrasound should be used with caution, at the lowest possible level of acoustic output and avoiding prolonged irradiation.



SPENGLER MEDICAL

30 Rue Jean de Guiramand
13290 Aix-en-Provence FRANCE



Lotus NL B.V.

Adresse : Koningin Julianaplein 10,
1e Verd, 2595AA, La Haye, Pays-Bas.
Tél : +31644168999
Email : peter@lotusnl.com

CE 1639



046-00001925-01